



ELECTRONICS SERVICE MANUAL

TABLE OF CONTENTS

	Page
I. AMPLIFIER	1
A. Description	1
1. Phono Preamplifier	1
2. Tone Control	1
3. Balance Circuit	1
4. Driver Amplifier	1
5. Power Amplifier	2
6. Power Supply	2
B. Biasing Procedure	5
1. Initial Adjustment	5
2. Distortion Measurements	5
C. Modifications and Updates	6
1. +20 Volt Regulator	6
2. Biasing Update	6
3. +39 Volt Lead Dress	6
4. AC Wiring	7
5. Driver Board	7
6. Phono Preamplifier	7
7. Tone Control Board	7
8. Turn-On Noise	7
9. Radio Frequency Interference (RFI)	7
10. Cautions and Suggestions	9
D. Specifications	13
II. TUNER	14
A. Description	14
1. Front End	14
2. IF Amplifier	14
3. Interstation Hush	14
4. Discriminator and SCA Filter	15
5. Multiplex Section	15
6. Power Supply	17
B. Tuner Alignment	17
1. Sweep Alignment	17
2. Discriminator Zero Setting	17
3. Mono Distortion	18
4. Mono Overload Distortion	18
5. Sensitivity	18
6. Multiplex Adjustments	18
7. Phase Adjustment	19
8. IF Filter Adjustment	19
9. Zero-Center Readjustment	19
10. Final Multiplex Adjustments	20
11. De-Emphasis Check	20
12. Pilot Dropout	20
13. Dial Calibration	21
14. Final Sensitivity Peaking	21
15. Interstation Hush and Stereo Squelch Adjustments	21
16. Final Performance Check	22

	Page
C. Modifications and Updates.....	22
1. Sensitivity Problems.....	22
2. Hush and Squelch Problems.....	22
3. Stereo Squelch Update.....	23
4. De-Emphasis Update.....	23
D. Dial Stringing Instructions.....	30
1. Görler.....	30
2. Waller.....	30
3. Final Adjustments.....	30
E. Specifications.....	32
III. RECEIVER.....	33
A. Description.....	33
1. Amplifier Section.....	33
2. Tuner Section.....	33
3. Input Selector Switch.....	33
4. Additional Features.....	33
B. Modifications and Updates.....	34
1. Amplifier Section.....	34
2. Tuner Section.....	34
IV. UNIVERSAL MODELS.....	42
V. TEST EQUIPMENT.....	42

LIST OF FIGURES

Figure No.		Page
1	Amplifier Schematic.....	3
2	Phono Preamplifier Board.....	10
3	Tone Control Board.....	11
4	Driver Amplifier Board.....	12
5	RFI Modifications.....	12
6	Tuner Schematic.....	25
7	Tuner Board.....	27
8	Front Ends.....	29
9	Dial Cord Stringing.....	31
10	Receiver Schematic.....	35
11	Power Amplifier Board/Biasing Update for Boards with Pots.....	37
12	Power Supply Board.....	38
13	IF Board.....	39
14	Multiplex Board.....	40
15	Tape Output Board.....	41
16	Universal Amplifier Transformer Wiring.....	43
17	Universal Receiver Transformer Wiring.....	44
18	Universal Receiver FM De-Emphasis for Units Without Tape Output Boards.....	44
19	Universal Tuner Transformer Wiring.....	45
20	Universal Tuner FM De-Emphasis.....	45

I. AMPLIFIER

A. Description

The following is a description of the amplifier circuitry. The circuit part numbers refer to the left channel of the circuit diagram, Figure 1.

1. Phono Preamplifier

The transistors Q1 and Q3 form a series-shunt feedback amplifier of which the closed loop gain is shaped with respect to frequency by the RC network: C13, C15, R15, and R17. This RC network conforms to RIAA specification, making the closed loop gain of the preamp +60 db at 20 Hz, +40 db at 1 kHz, and +20 db at 20 kHz. The pot R19 adjusts the preamp overall gain by approximately 6 db. (See Figure 2.)

2. Tone Control

The transistors Q5 and Q7 are connected in modified Darlington configuration for high input impedance and approximate gain of 9.5 db. The modified Baxandall negative feedback tone control is formed by pot R41; resistors R35, R47, R39, R37, R43; pot R45; network RC-1; capacitors C21, C23; transistor Q9 and its associated biasing resistors. R41 is used for bass control while R45 is the treble control. (See Figure 3.)

3. Balance Circuit

The balance circuit comprises Q27 and its associated biasing resistors R105, R104, R123, R116, and front panel balance control pot R106 and mode switch S3.

When the mode switch is placed in null position and a mono signal applied, Q27 will invert the signal from the right channel, as well as maintain unity gain. This signal then is summed with the signal from left channel of the same amplitude, but 180° out of phase, at the junction of R109 and R103. Now, if the balance control is set at center and signals coming from the tone control are equal in amplitude, then the summed signal will be minimum, and a null will occur, which will indicate an aural balance. (See Figure 3.)

4. Driver Amplifier

The driver amplifier consists of transistors Q11, Q13, Q15, and Q17; T3's primary; and the associated biasing resistors. Q11 is an emitter follower presenting a high input impedance to incoming signals and a low source impedance to the driver stage. Q13 is the main gain stage (bootstrapped amplifier) whose open loop gain is 48 db. Q15 and Q17 form a complementary follower, combining Q13 and Q17 which are a class AB amplifier.

The closed loop gain of the driver stage is determined by the complex shunt feedback network - R61 in parallel with series network of R63, C37 and the complex source impedance which is made up of C35, L1, and R59. For low frequency gain, that is, from 10 Hz to 200 Hz, R61 and the reactance of C35 determine the closed loop gain. Above the midband (5 kHz to above 40 kHz) the reactance of C37 in series with R63, and L1 in parallel with R59, become dominant gain setters. The function of D11 and D13 is to restore DC when Q13 is overdriven by large transients.

The capacitor C39 maintains a constant voltage drop across R71 and R69 during dynamic operation of the amplifier. This action is sometimes referred to as bootstrapping. Since there is no AC across R71 and R59 they do not draw AC current and thus act as much larger resistors for AC, while retaining their rated resistance for DC. R119 sets the proper source resistance to T3's primary. (See Figure 4.)

5. Power Amplifier

The power stage is a single-ended push-pull amplifier. Transistors Q19 and Q21 act as beta-multipliers for the output power transistors Q23 and Q25, as well as impedance matching. To provide temperature compensation silicon diodes D1 and D3 are in physical contact with emitter resistors of the output power transistors. The resistors R97 and R99 are used to improve linearity of the output stage. The power amplifier is biased for a conduction angle between 180° and 190° for minimum crossover and IM distortion. Transformer T3 acts as impedance matcher, phase inverter, and isolator of load from the driver stage. The turns ratio of T3 is 1.3:1. The overall loop gain of the power amplifier is set by the complex impedance of C41, R75, and R67 for 33 db. This negative feedback also reduces distortion. The series network R101/C45 rolls off the amplifier output at supersonic frequencies, and improves stability should a speaker become accidentally disconnected.

6. Power Supply

The main unregulated supply, which operates the power amplifier stage, is a split full-wave type delivering ± 39 V DC. This supply consists of T1, D5 through D8, C49, and C50. All remaining circuitry operates from a +20 V DC regulated supply, which consists of R113, C51-A, C51-B, R114, D9, and Q28.

Suppressor Supply: This supply operates continuously, independent of the power switch, and minimizes undesirable turn-on noise. It is a full-wave type, and consists of T4, D14, D15, C36, R115, C51-C, and D16. The supply operates the phono preamp and the output stage of the driver amplifier and delivers +17 V DC. When the power switch is turned on, the +20 V DC supply causes D16 to conduct and effectively takes over the circuits which the suppressor supply operates.

Thermal Protection: Circuit breakers CB-1 and CB-2 are fastened directly to the cases of the output transistors. If the transistors overheat due to either sustained clipping or circuit malfunction, the breakers will open, thus interrupting the line voltage fed to T1. The breakers reset themselves upon the restoration of normal temperatures.

FIGURE 1
AMPLIFIER SCHEMATIC

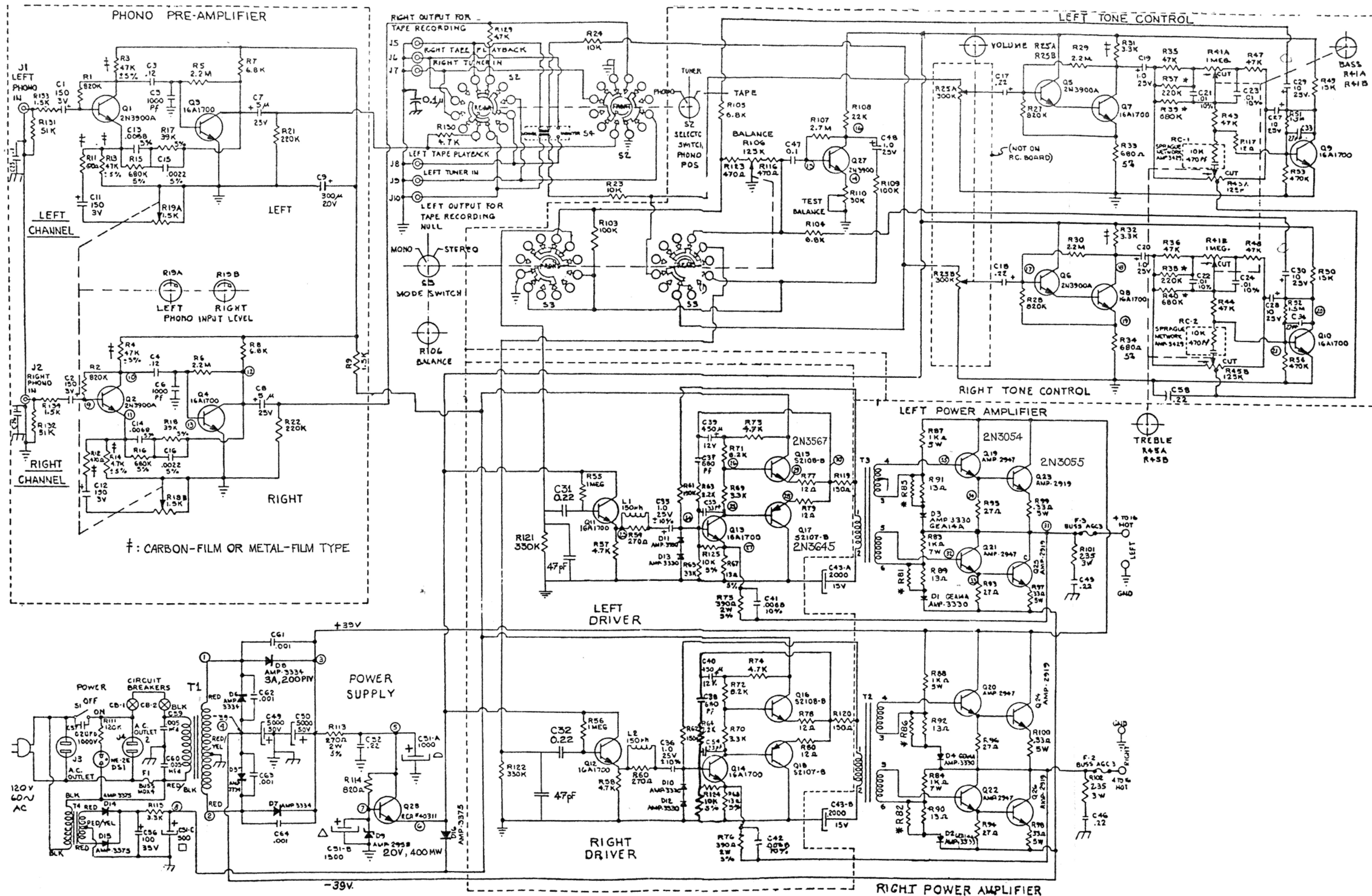

B. Biasing Procedure

The quiescent collector currents in the output transistors Q23 and Q25 are determined by the voltage dividers R87/R91 and R83/R89. The 13 ohm portions of these dividers are shunted by fixed resistors whose values are selected so that the amplifier has low IM distortion and reasonable operating temperature. If the amplifier has pots in place of these 13 ohm resistors, update the amp following instructions in Part I.C.2.

1. Initial Adjustment

Make sure that the diodes D1 and D3 are secured to the 0.33 ohm power resistors R97 and R99. If loose, the bias will drift, causing thermal runaway. Check the silicone grease on the driver and output transistors for a thin, even coat on both sides of the mica or anodized aluminum insulators. Also check the mounting screws for tightness. Tack-solder four 0.5 watt resistors across the four 13 ohm resistors. These can be any value between 33 and 51 ohms, but should be the same value within a channel. These resistors, as well as the 13 ohm ones, should be carbon or metal film types for temperature stability. However, common carbon composition types can be used. AR used Corning glass-coated metal film resistors in production.

The initial DC offset adjustment requires the use of an audio test rack, which has switches to disconnect the dummy loads while retaining all other test equipment connections. Also it should have a left-right monitor switch which feeds the equipment. Either a DC-coupled oscilloscope or sensitive DC voltmeter is required for this test, having a 250 mV full-scale range or less. A zero-center type is most convenient.

Connect the amp to the rack, leaving the loads off. Turn the amp on, keeping the volume fully down. Touch the leads of a 150 to 200 ohm resistor across each of the four parallel resistor combinations and note which ones thus shunted tend to reduce the offset in each channel. Turn the amp off. Replace the 33 to 51 ohm shunt resistors, noted above (one in each channel), with one or two values smaller. For example, if a 47 ohm resistor was initially chosen, replace it with a 43 or 39 ohm resistor. Another way to reduce the offset is to increase the other shunt resistor. Turn the amp on and recheck the offset. If it is 100 mV DC or less, proceed with distortion measurements.

2. Distortion Measurements

Having achieved DC offsets of less than 100 mV DC in both channels, connect resistive dummy loads of 4 ohm, 100 watts. Note that the offset decreases considerably; this is normal. If a voltmeter was used to measure offset, disconnect it or it will be damaged in the following test. Replace the standard AGC-3 speaker fuses with 4-amp slowblow fuses. Connect a SMPTE-type IM distortion analyzer across the dummy loads and to the amplifier's tuner input jacks. Turn the volume control to the 3 o'clock position, and increase the IM analyzer's generator output until the output is just below clipping. The IM distortion must be 0.25% or less. Reduce the amplifier's volume until 3 V RMS output is obtained. The IM distortion must be 0.25% or less at this level also.

With the simple output stage circuitry, there is a tradeoff between distortion and quiescent current. As the adjustable shunt resistors R81 and R85 are made smaller, the quiescent current (and therefore the temperature) in the output transistors is decreased, but the crossover-notch distortion increases. This affects the IM distortion, especially at low levels. If the resistors are increased, the distortion decreases, but the temperature increases.

It has been determined from production experience that the shunt resistors should be between 30 and 62 ohms, if R89 and R91 are 13 ohms. Some amplifiers were built with 12 ohm resistors, and for these the suggested shunt range is 36 to 82 ohms.

After the amp has achieved the IM distortion specification, recheck the DC offset with dummy loads disconnected. This will drift somewhat with temperature, but the final shunt adjustment should be made when the heat sinks are moderately warm, not hot. The harmonic distortion must be 0.5% or less at clipping and at 3 V RMS output, but typically will be 0.1%. Both IM and THD will be somewhat lower with 8 and 16 ohm loads. Return the standard AGC-3 fuses to the speaker fuseholders.

C. Modifications and Updates

1. +20 Volt Regulator

Early production amplifiers used S2108 (2N3567) transistors for Q28 and these often failed. Replace it with RCA #40311, a metal TO-5 style. Also change collector resistor R113 to 270 ohm, 1 watt; and zener series resistor R114 to 820 ohm, 0.5 watt.

2. Biasing Update

Early production amps and receivers used carbon pots to adjust the bias. These became intermittent with use and also had a considerable temperature coefficient. Two circuits were employed: a 50 ohm pot across a 33 ohm resistor, and a 5 ohm pot with a 9.1 ohm series resistor.

For more stable bias, update the circuit as follows:

- Using a 1/8" to 1/4" drill, remove the rivets which fasten the pots, working inside the chassis. Shake out any metal particles which remain inside; these could cause short circuits. Clip the leads connected to the pots, leaving as much wire remaining in the amp as possible. Discard the pots.
- Install four terminal strips on the chassis, using any of the rivet holes which allow the clipped leads to reach the terminal strip lugs. Each strip should have two lugs insulated from the mounting foot. Connect one 12 or 13 ohm, 1/2 watt resistor to each strip, leaving room for the shunt resistors which will be connected later.
- To update a receiver, remove the bias pots from the power amp boards. If one is careful this can be done without removing the boards from the heat sinks. Install jumper wires and 12 or 13 ohm, 1/2 watt resistors, as shown in Figure 11.

3. +39 Volt Lead Dress

To prevent buzz in the output, especially with low AC line voltages, change the +39 V wiring to the driver/output stages. The red wire from C50 (5,000 μ F), goes to terminal #7 (below terminal #4) of the left-channel driver transformer T3. It then goes to the collector of Q19, then to the collector of Q20, and finally to terminal #7 of the right-channel driver transformer T2. T3 and Q19 are closest to the power transformer. The #7 terminals serve only to support R87 and R88, the 1k resistors in the bias divider, but do not connect internally to the transformer windings.

4. AC Wiring

Route the power switch wiring to the right side of the volume control. Change R111, the neon lamp series resistor, to 33k, 1/2 watt.

5. Driver Board

Early production amps had 2k7 for R63 and R64. Change these to 2k2. If operating the mode switch (mono-null-stereo) causes pops in the speakers, add the following parts: 47 pF capacitors across R121 and R122 (330k); 33 pF capacitors between bases and collectors of Q13 and Q14.

A common problem with the driver board is an intermittent dead channel. This symptom can take as long as several hours to develop; then the bad channel starts to cycle on and off. To simulate the problem, hold a hair dryer or the tip of a 60 watt soldering iron close to (not touching) Q15 and Q17. If both transistors can withstand this heating for 10 to 15 seconds, they are good. However, if defective, this will cause the channel to stop working almost immediately. If a bad transistor is found, always replace both in that channel. Q15 can be replaced with Fairchild SE-6020 or 2N3567 (any manufacturer). Q17 can be replaced with a 2N3645.

6. Phono Preamplifier

To reduce noise change R3, R4 (47k), R11, R12 (470 ohms), and R13, R14 (4k7) to metal or carbon-film types. If noise persists, change the transistors. Any NPN small-signal type will work, but Texas Instruments #TI S-97 is commonly available.

7. Tone Control Board

To reduce noise, change R31, R32 (3k3) to metal or carbon film type. To cure popping in speakers as mode switch is operated, add 27 pF capacitors from base to collector of Q7, Q8. See also Part I.C.5.

8. Turn-On Noise

There are many sources of turn-on noise, but most of them can be attributed to defects in the suppressor supply. With the amplifier plugged in to an AC outlet, but not switched on, there should be about +17 V DC at test point 8 (see Figure 1). There should be 0 V DC at test point 6. If there is any voltage at test point 6, change D16. This can be a 1N914 or 1N4148.

Virtually all turn-on problems remaining can be cured by replacing entirely, or adding capacitance to, C56. This is the main suppressor filter. Make this cap as large as possible. The diodes D14 and D15 may have to be relocated, to allow the new cap to fit.

9. Radio Frequency Interference (RFI)

The following modifications will eliminate most cases of citizens band and amateur radio interference. (See Figure 5.)

The amplifier has only one chassis ground, located between the main $\pm 39V$ filter capacitors, to eliminate ground loops. The shells of the input jacks are not connected directly to the chassis where they are attached to the rear panel, but are grounded via a 10" length of wire. This places them above ground at RF frequencies, even though they have a low resistance connection at audio frequencies.

For this reason, a factory modification was made which bypasses the jack shells directly to the chassis through $0.1 \mu F$ capacitors. However, for maximum effectiveness, the capacitor lead length should be as short as possible, and the grounding point should be clean and tightly secured. Not all of the factory-updated amps meet these requirements. In most cases the capacitor lead length is over 1" and they are soldered to rivets which mount the input jack board to the chassis. The resistance between the rivet head and the chassis increases with time, in a nonlinear manner, causing rectification of RF signals. The solution to this involves removing the rivets and replacing them with machine screws.

- Remove the knobs and $9/16"$ hex nut from the phono gain pot, unsolder the leads going to the phono input jacks, and remove the screw which attaches the phono preamp board. Remove the fiber standoff spacer and two screws which attach the driver board. Move both boards out of the way. With a $1/8"$ drill remove the rear portion of the four rivets. A variable-speed electric drill of $1/4"$ capacity is ideal for this. Remove the input jack board from the chassis. Carefully remove the black aluminum plate (containing the legends which identify the jacks) from the rear of the chassis. If the rivets do not come out easily, use a $1/8"$ or smaller pin punch from inside the chassis. Remove all of the adhesive from the chassis which secured the aluminum plate, especially around the rivet holes.
- Each jack shell has a ground lug, and both are swaged onto the board. Since this is a pressure connection, it is subject to the same resistance increase as the rivets, mentioned above. Solder all 8 shells to their lugs, using separate flux if necessary. Attach 3 disk ceramic capacitors to the jacks, as shown in Figure 5. Factory-modified amps used Sprague Ultracaps – $0.1 \mu F/10 V$ – but any value of $0.01 \mu F$ or higher is suitable. Reattach the board to the chassis, using #3-48 or #4-40 machine screws, $3/8"$ long. A round head style screw is preferred, since a pan or binder head type may be larger than the clearance hole in the aluminum plate. Place internal-tooth lockwashers under the screw heads to ensure a low-impedance RF ground. Reattach the aluminum plate.
- Most RFI problems occur in the phono preamp, since this has higher gain. The addition of miniature toroidal ferrite beads to the preamp is suggested. Resistors R131 and R134 were not installed in all amps; a wire replaced them. If these resistors are put in with ferrite beads close to the resistor body, an effective pi-section filter is created which will pass audio frequencies, but block RF (see Figure 5). Additionally, the beads can be slipped over the base leads of all 4 preamp transistors, if interference persists. Should the RFI occur on the high-level inputs (tuner and tape) place beads over the six lower input jack leads. Secure these on the wires with adhesive, since they are most effective when close to the jacks. Further measures involve placing beads over the base leads of tone board transistors.

10. Cautions and Suggestions

a. **0.22 μ F Capacitors:** If an amp, tuner, or receiver has General Electric 0.22 μ F mylar capacitors, take care to bend the leads as little as possible where they enter the capacitor body. This can open the cap.

b. **5,000 μ F/50 V Electrolytic Capacitors:** Some brands of these caps, used as main ± 39 V filters, have higher equivalent series resistance (ESR) than others, resulting in various buzzes and pops, especially with low line voltages. The Industrial Condensor Corp. Royalitic caps are especially prone to this problem. The solution is to wire a 0.22 μ F (or greater) mylar, ceramic, or dipped-mica cap across them, especially the +39 V filters.

c. **Tape Monitor Switch:** Whenever an amp or receiver is serviced for any problem, it is a good idea to clean the tape monitor switch. Also, suggest to the owner that they operate the switch occasionally, whether or not they use it, since all of the inputs pass through this switch.

d. **Pinching Wires:** If for any reason the heat sinks must be removed or loosened from the chassis (to more easily remove the output transistors or circuit breakers), make sure that no leads are pinched under the heat sinks when reinstalled.

e. **Overheating:** If an amp or receiver frequently overheats and operates its thermal breakers, check the silicone grease and hardware tightness (refer to Part I.B). This can happen even if the unit is not delivering power to the speakers, i.e., under quiescent conditions. If a unit has the biasing update installed, there should be no overheating due to resistance changes in the bias divider resistors. Any unit which has bias pots that overheats quiescently must be updated.

FIGURE 2
PHONO PREAMPLIFIER BOARD

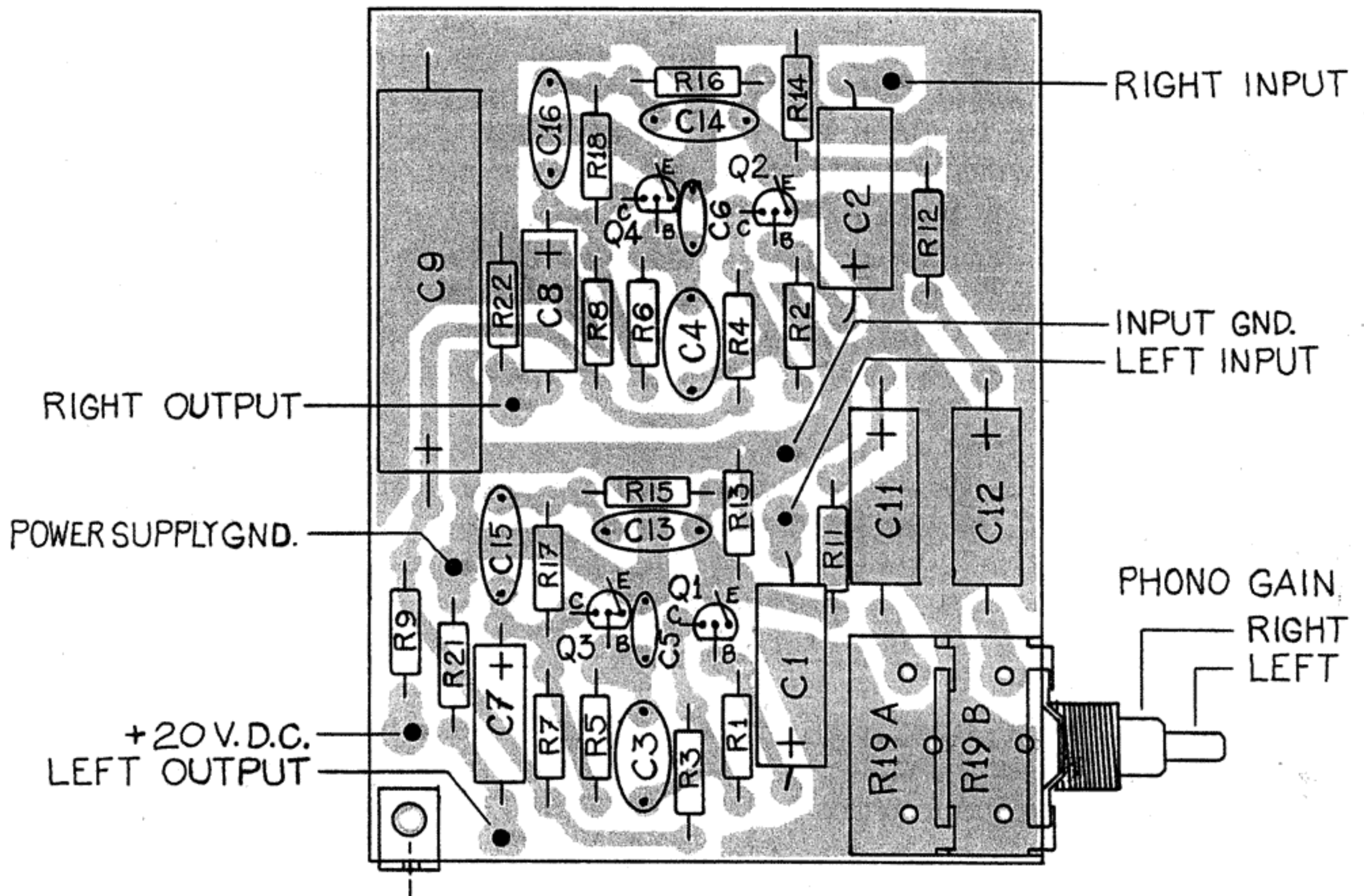
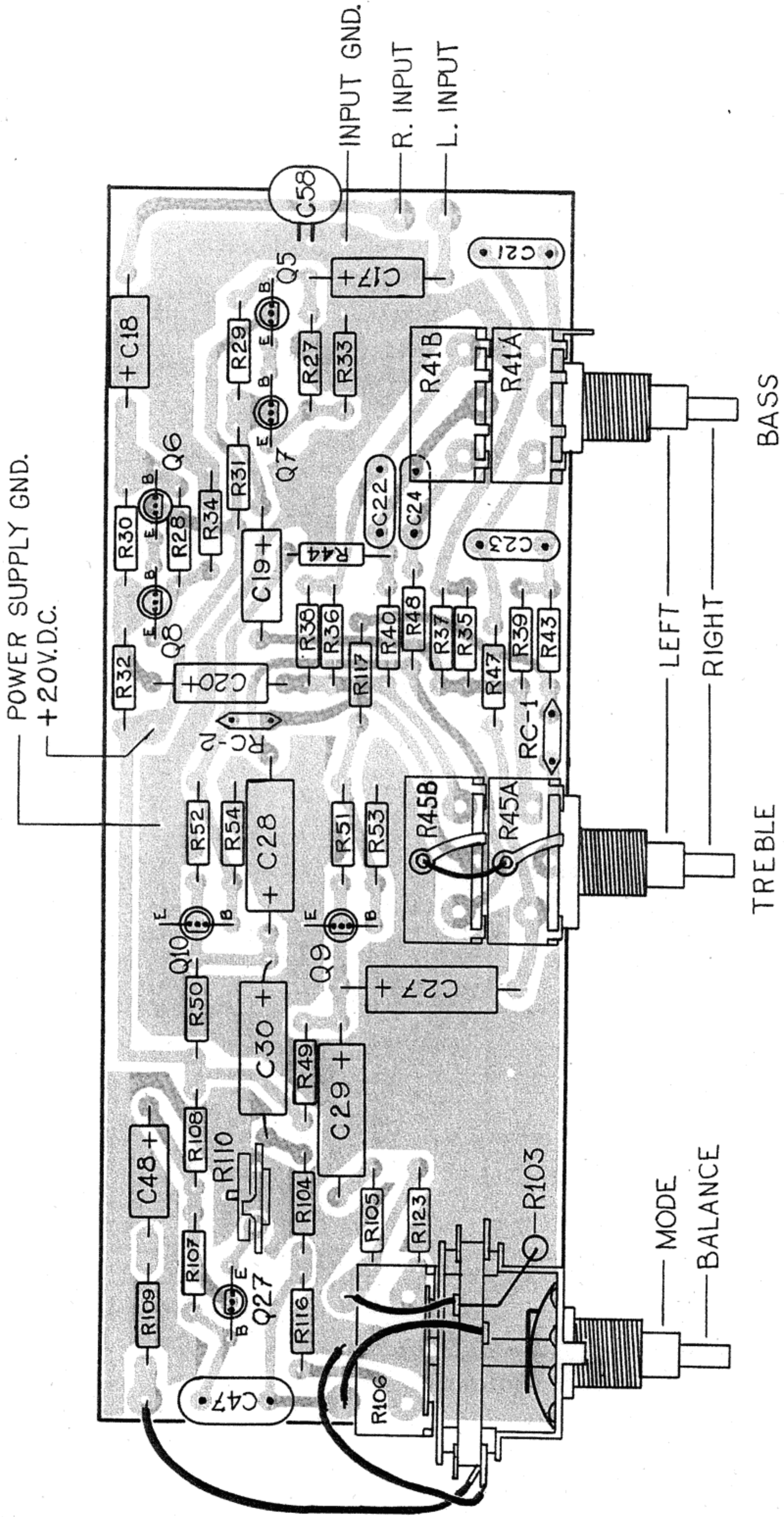
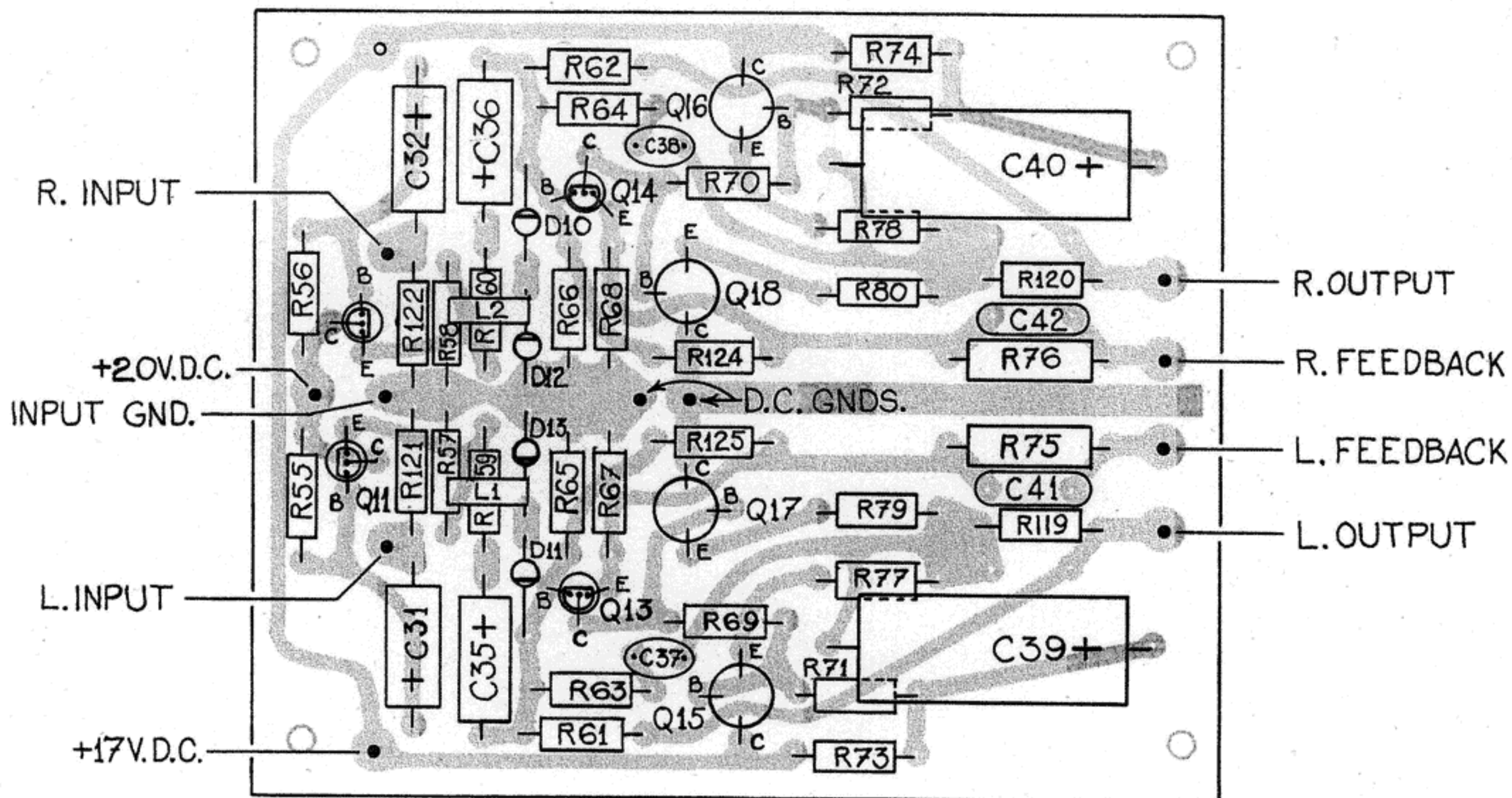

FIGURE 3
TONE CONTROL BOARD



**FIGURE 4
DRIVER AMPLIFIER BOARD**



**FIGURE 5
RFI MODIFICATIONS**

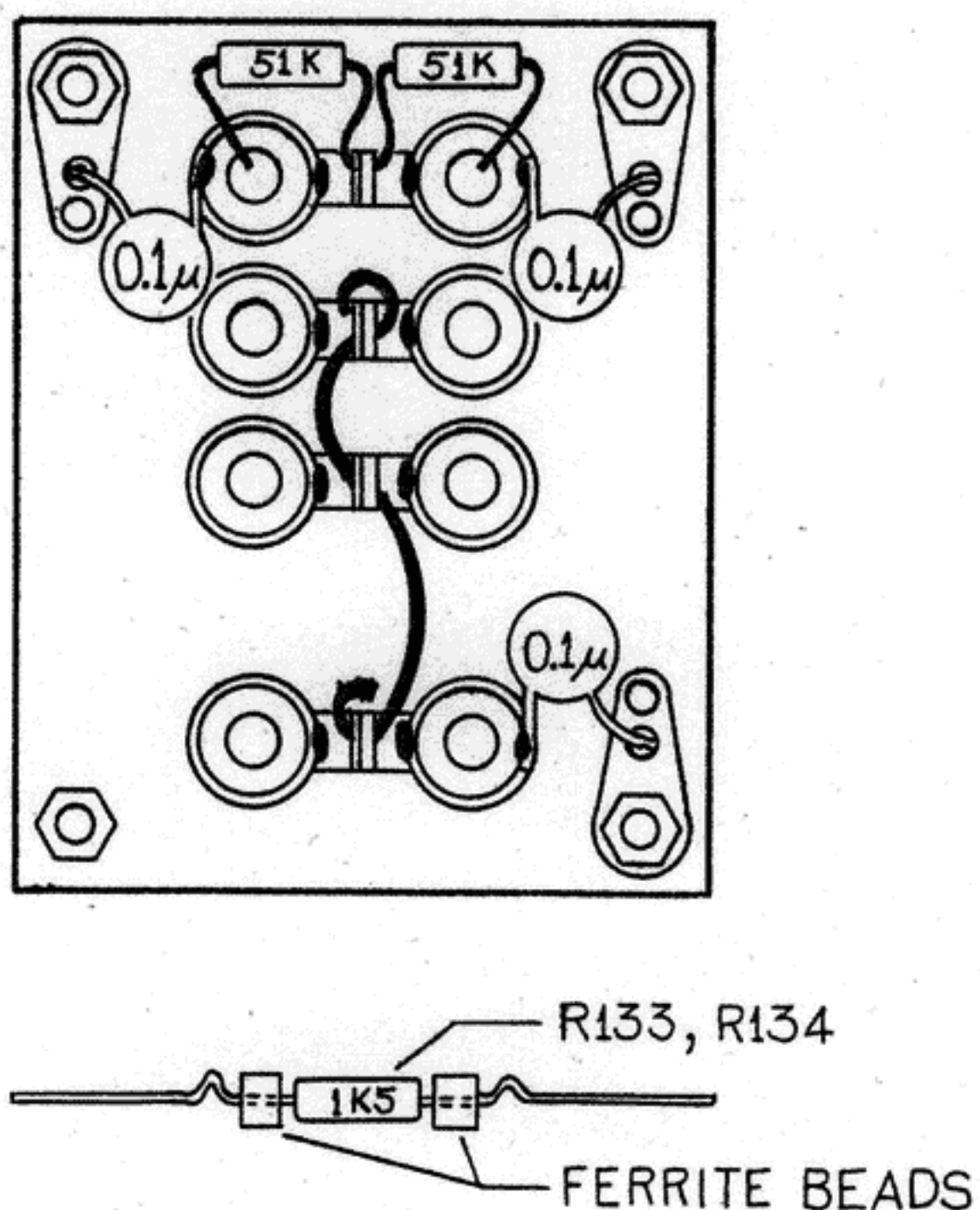

D. Specifications

- **Power Output:**
 - 60 watts RMS/channel into 4 ohms
 - 50 watts RMS/channel into 8 ohms
 - 30 watts RMS/channel into 16 ohms

The amp can deliver these power levels at any frequency from 20 Hz to 20 kHz, without exceeding the distortion specs, both channels driven.
- **Distortion:**
 - IM (SMPTE, 60 and 7 kHz, 4:1) less than 0.25%
 - THD less than 0.5%

Distortion figures include the phono preamp.
- **Frequency response:**
 - ±1 db, 20 Hz to 20 kHz, with tone controls flat.
- **Signal/Noise Ratio:**
 - Phono input: -57 db (ASA "C" weighted)
 - High-level inputs: -75 db (ASA "C" weighted)

Ratios are with volume control at maximum, with shorted inputs.
- **Input Impedance:**
 - Phono inputs: 50k ohms, shunted by 20 pF or less.
 - High-level inputs: 150k ohms.
- **Input Sensitivity:**
 - Phono inputs: 2 to 5 mV RMS, adjustable
 - High-level inputs: 200 mV RMS

Input levels are those which drive the amp output to rated power with the volume control at maximum.
- **Input Facilities:**
 - Magnetic phono, tuner, tape, and output for tape recording.
- **Damping Factor:**
 - 8 to 20 into 4 ohm loads
 - 16 to 40 into 8 ohm loads
 - 32 to 80 into 16 ohm loads

Lower figures apply at 20 Hz, higher figures apply from 75 Hz to 20 kHz. Factors include AGC-3 speaker fuses.

II. TUNER

A. Description

The following is a description of the tuner circuitry. The circuit part numbers refer to those in Figure 6.

1. Front End

Two types of front ends are used: Görler (German) and Waller (Japanese). The Görler uses JFETs and the Waller uses diode-protected MOSFETs. The type of front end can be determined by noting the tuning scale linearity. The Görler is almost perfectly linear, with slight compression at the 88 MHz end, whereas the Waller is noticeably compressed at the 108 MHz end. Both types feature four-section tuning capacitors.

2. IF Amplifier

The tuned secondary of the 10.7 MHz IF transformer inside the front end is resonated by a series capacitive divider to minimize loading by the following gain stage. Q1 (2N3855) and its related components assembled on the front end provide 30 db of gain. This gain is needed to compensate for the loss of signal level in the capacitive voltage divider, and for the insertion loss in the following bandpass filter, FL3. The signal then passes through the bandpass filter, FL3, via R5. Three different filters are used:

Gray crystal	(part #R4051)	Z in = Z out = 1,000 ohms
Blue crystal	(part #R4141)	Z in = Z out = 500 ohms
Gray LC	(part #20042)	Z in = 500 ohms, Z out = 1,000 ohms

Trimmers C5 and C7 are adjusted for best phase linearity, and resistors R5 and R6 control the band width of the linear region.

Integrated circuits IC1 and IC2 are linear amplifiers each providing 60 db of gain, but they fully limit when their inputs exceed 600 microvolts. Q4 (2N3855) drives the discriminator transformer. The DC voltage at the base of Q4 is normally positive (with respect to the emitter), causing it to conduct. RF antenna signals weaker than the squelch pot threshold setting will allow internal noise from IC1 to be amplified by the squelch amplifiers Q2 and Q3. Only noise over approximately 100 kHz is amplified, because of bandpass networks L1, L2 (540 μ H) and C23 (1,000 pF), C1 (560 pF). This noise is detected and filtered in the positive direction by CR3, CR4, and C34. The filtered voltage is then sent to two circuits, the interstation hush and stereo squelch stages. The stereo squelch stage will be described later in Part II.A.5.c.

3. Interstation Hush

Hush pot R23 (300k ohms) applies the DC noise voltage to the base of Q6. This causes Q6 to conduct, pulling its collector down. The emitter of Q4 is normally held at about +3 V DC by R20 (2k2) and R21 (510 ohms). Q4's base is pulled down via R19 (100k) and R22 (4k7), along with Q6. This mutes or hushes the discriminator output whenever the incoming antenna signal is too weak to compete with normal random thermal noise from IC1.

4. Discriminator and SCA Filter

The discriminator is a wide band, balanced Foster-Seeley phase detector, with a peak-to-peak separation greater than 1 MHz. Careful construction and balancing of components gives excellent linearity, ensuring low distortion and capture ratio. The discriminator is loaded by the series resistors R25 and R26 (8k2), in parallel with the center-tune meter's resistor R27 (39k). This is equivalent to a 11k5 load. The center tune meter reads relative tuning error on either side of the nominal resonant frequency, to which the discriminator has been aligned.

The recovered audio (and 19 kHz pilot subcarrier) is sent to Q5, an emitter follower stage, whose low output impedance is matched by R31 (9k1) into the input impedance of the SCA filter L3, C40, and C41. This filter prevents leakage of the 65 to 67 kHz subcarrier, used by stations providing commercial-free background music, which could cause audible interference to the normal programming.

5. Multiplex Section

Following the SCA filter, the composite signal goes to Q7 which splits the signal into two parts.

a. Pilot Amplifier: The collector of Q7 feeds a tap on L4 which is made adjustable so that it may be resonated with C42 (0.01 μ F, polystyrene) at 19 kHz. (Continued in Part II.A.5.c.)

b. Composite Signal Amplifier: Q7's emitter develops a voltage slightly less than its base voltage across R84 (680 ohms). R35 (2k7) and R36 (22k) form (approximately) a 1:8 voltage divider between the emitter and collector of Q7. For all frequencies other than 19 kHz, there is negligible voltage at Q7's collector, so the output at the junction of R35/R36 is about 8/9 of the emitter output. $22k/(22k + 2k7) = 8/9$. With a 19 kHz signal, the impedance of the portion of L4 in Q7's collector is 8×680 ohms or 5k4 ohms. The 19 kHz signal level at the collector will likewise be 8 times the level at the emitter, but 180° out of phase. The 1:8 divider nulls only the 19 kHz signal without affecting the audio frequencies or the 38 kHz chopping rate. This composite signal, stripped of 19 kHz energy, is sent via two paths:

- Multiplex Chopper Feed: The composite signal is sent to R54 (47k), via C50 (10 μ F). (Continued in Part II.A.5.d.)
- Stereo Gain Compensator: The composite signal is sent through R56 (1k2) and C51 (10 μ F).

In mono operation, current from R53 (8k2) makes double-diode CR5 (G.E. STB-567) conduct, providing a low impedance path to ground. This provides an AC load of about 1k5 ohms to the junction of R35/R36. Since the source impedance of this junction is about 2k7 ohms, the signal at C50 is about 1/3 of that at the junction. $1k5/(1k5 + 2k7) = 0.357$.

In stereo operation Q13 conducts, the stereo light goes on, and the DC voltage at the junction of R52/R53 (2k7/8k2) falls. CR5 no longer conducts, and the gain compensator components R56 and C51 no longer have a low impedance ground path through CR5. They must find a new AC ground through R53 (8k2) and C49 (5 μ F). This new, higher impedance path is 8k2 ohms more than the mono impedance of 1k5 ohms, or

9k7 ohms. Now the signal level at C50 is seen to be $9k7/(9k7 + 2k7) = 0.782$, or about twice the mono value. This increase is needed in stereo to compensate for the 2:1 loss in output resulting from the chopper's property of shorting the signal during its 50% on-time. This would render stereo broadcasts 6 db weaker than mono, unless compensated.

c. Pilot Amplifier (Continued): The collector of Q7 is current amplified by emitter follower Q8, and sent to Q10, which has a resonant circuit L5/C44 in its collector.

Stereo Squelch: The detected and filtered noise voltage, described previously, is sent via R32 (10k) to the squelch pot R33 (300k). A portion of this voltage (the amount depending upon the pot setting) is sent via R34 (10k) to the base of Q9. Upon receiving sufficient voltage, Q9 will conduct. This collector current, drawn through R37 (1k) and R39 (100 ohms), will cause enough drop across R39 to make Q10's emitter go negative with respect to its base, cutting off Q10. This interrupts the 19 kHz chain. R83 (1M8) pulls Q9's base slightly positive into the conduction region. This pulling effect is reduced when Q11 conducts and increases the drop across R41 (1k5), only in stereo. Q11 is fed by the tap on L5, and since both Q11's base and emitter are grounded, it is cut off without 19 kHz present. When a 19 kHz signal arrives and Q10 conducts, the pilot signal will reach the base of Q11 and positive peaks will drive Q11 into conduction. The collector load for Q11 is a double tuned 38 kHz transformer; C46 and Q48 respectively tune the primary and secondary. Both are 0.01 μ F polystyrene type for stability. When Q11 is driven into conduction and doubling, its collector current causes a drop in R41 (1k5) which pulls the base of Q12 negative, with respect to its +11 V emitter. This causes Q12 to conduct, its collector goes positive, driving Q13 into conduction, lighting the stereo lamp. This lowering of Q13's collector voltage increases the gain in stereo 6 db over the mono gain and, via the voltage divider R46 (15k) and R43 (1k2), pulls the bases of the chopper transistors Q14 and Q15 down enough (from their higher mono condition) that the choppers conduct alternately, as they receive negative 38 kHz half pulses from T2.

d. Chopper (Multiplex Decoder): The bucking-out property of Q7's inverting collector, in conjunction with the 1:8 divider formed by R35/R36, strips the composite signal of 19 kHz energy. The remaining composite is sent via C50 (10 μ F) and R54 (47k), through R57 (15k) to Q14's collector, and through the parallel combination of R55 (47k) and the stereo balance pot R58 (30k), to Q15's collector.

As the 38 kHz signal makes Q14 and Q15 alternately conduct, they short out the signal at their collectors. The remaining collector signal is the composite wave's left or right half pulse information. Q14 shorts out the right half pulse information, leaving the chopped left signal, while Q15 shorts out the left half pulses leaving the chopped right signal. The average value of these two pulse type stereo output signals is 6 db with respect to a full time monophonic signal of equal peak to peak value. Because the decoder is not 100% efficient, and there is some high frequency droop, emitter-to-emitter cross matrixing is used to remove any residual crosstalk. This matrixing is formed by the parallel combination of R94 (1k5) and R64 (2k) (the separation adjustment pot), between the emitters of Q16 and Q17. The bases of these transistors are fed cleaned-up audio signals via networks R59 (4k7)/C52 (47 pF) and R60/C53.

e. Output Stage: The recovered audio next passes through 15 kHz low pass filters FL1 and FL2, which remove (largely) the remaining 19 kHz and 38 kHz residual energy. They are LC elliptic-function types. De-emphasis is provided by R88 (6k8) and C58 (6.8 nF) in the right channel, and R89/C60 in the left. Resistors R99 and R100 provide a "step," to maintain flat frequency response in the 15 kHz region. R71 (dual 100k pot) provides variable output to the emitter followers Q18 and Q19.

6. Power Supply

The power supply is a full-wave type, providing +12 V DC, +20 V DC, and for tuners having a Görler front end, +24 V DC. +12 V DC regulated is supplied from Q20, a zener-referenced series-pass regulator. +20 V DC unregulated is supplied from Q21, a capacitance multiplier, and is current limited. +24 V DC is derived from Q21's collector.

B. Tuner Alignment

High-quality equipment is needed to properly align a tuner. It should have residual distortion of no more than 0.2% THD in mono, 0.3% in stereo, and the RF attenuator must be capable of accurately reading to below 1 microvolt. An oscilloscope having a band width of 150 kHz minimum is required. A simple RF detector probe can be built to facilitate sweep alignment. (See Figure 7.) Refer to Figure 8 to identify the location of the front end slugs and trimmers.

1. Sweep Alignment

Connect the detector probe to the output of IC1, as shown in Figure 6. Connect the probe output to a DC-coupled oscilloscope, set for 50 mV/cm sensitivity. The scope's horizontal input is driven from the FM generator's audio synch output. Adjust the FM generator to 100 MHz, ± 210 kHz deviation, 80 Hz modulation (mono), and 10 μ V output. Set the tuner to mono, hush off, and power on. Tune the tuner so that the sweep bandpass pattern is centered on the scope face; also adjust the scope's horizontal position control for symmetrical deflection around the center. The RF level of the generator may have to be reduced as the tuner sensitivity is improved. Keep the pattern about 4 cm high.

Adjust the following four slugs in the front end for highest gain: antenna, RF amp output, mixer input, and 10.7 MHz secondary (top slug). (See Figure 8.) The 10.7 MHz primary (bottom) slug has two peaks. Choose the upper peak, and adjust it to minimize tilt across the top of the pattern.

Adjust the crystal filter's trimmers C5 and C7 for best symmetry on the top of the pattern, and readjust the primary slug for least tilt. If the bandpass pattern appears to be best at the maximum or minimum setting of the trimmers, remove or add enough 6.8 pF caps to bring the best setting nearer to the midpoint of the trimmer's range.

2. Discriminator Zero Setting

With the apparent axis of symmetry of the top of the pattern centered horizontally on the scope face, slowly reduce the deviation of the generator. Observe that the pattern appears to expand symmetrically about the center. Set the deviation to ± 75 kHz and the output to 1k μ V. Remove the sweep probe, and connect the scope to the output of a harmonic distortion analyzer, which in turn connects to the tuner output jacks. The probe must be disconnected at this time, as it mutes the tuner's audio output. Adjust the discriminator primary (top) slug for an exact zero-center indication on the tuning meter. Be very careful not to disturb the tuning knob, flywheel, or front-end drum when adjusting the slug.

3. Mono Distortion

Adjust the discriminator secondary (bottom) slug for least distortion. If the alignment tool can be gently lowered past the top slug without disturbing it, then the bottom slug can be adjusted from the component side of the board. This is a delicate operation, and it is easier to adjust the slug from the foil side.

Note: Tilting the tuner on its side can slightly flex the chassis, disturbing the tuning. A better method is to support the tuner above the test bench, high enough to gain access to the foil side. The distortion must be 0.25% or less; typically it will be less than 0.1%. The zero-center and distortion adjustments interact somewhat; readjust the centering if necessary.

4. Mono Overload Distortion

Increase the generator output to 100k μ V, and note that the distortion does not exceed 0.5%. Readjust the 10.7 MHz secondary (top) slug slightly, if necessary, for lowest distortion. If greater than 1/4 turn is necessary, monitor the audio output level while turning the slug. There is a false distortion-null point, where the audio output decreases 1 to 2 db compared to the 1k μ V level. This cannot occur if the primary (lower) slug is correctly set to its upper peak.

5. Sensitivity

Reduce the generator output until the noise plus distortion of the audio output rises to 3.2%. This corresponds to -30 db of quieting, the Institute of High Fidelity Manufacturers (IHFM) standard. The attenuator dial should read 2.0 μ V or less, but if it is 3 μ V or less, this will suffice for now. Readjust the 10.7 MHz primary (bottom) slug slightly, if necessary, for the most symmetrical noise pattern. Also adjust the antenna, RF amplifier, and mixer slugs for best sensitivity.

If there is any regeneration in the IF amplifier or discriminator stages, the sensitivity spec cannot be achieved. Referring to Part II.C.1, perform all of the steps described before attempting final peaking.

6. Multiplex Adjustments

Return the generator to 1k μ V output, turn the audio modulation off, the 19 kHz pilot on (preset to 10% modulation), and reduce the deviation control to minimum. Set the tuner to the stereo mode.

Connect the scope to 19 kHz test point 2 in Figures 6 and 7, using a straight, non-attenuating probe. Set the scope for 200 mV/cm. Advance the deviation control until a 19 kHz pattern appears on the scope, 3 cm high. Alternately adjust the first (L4) and second (L5) coil slugs for maximum output. Keep the pattern 3 to 5 cm high, using the deviation control.

Connect the probe to 38 kHz test point 3, return the deviation control to the point which produced ± 75 kHz deviation when the modulation was on, and set the scope for 1 V/cm. Adjust upper and lower slugs in the 38 kHz transformer T2 to produce maximum output. There are three combinations of slug positions which produce resonated conditions. Choose the upper positions for both slugs, as this will give highest output. Remove the probe from the 38 kHz test point, as it unbalances the chopper drive, affecting the next steps.

7. Phase Adjustment

Set the generator as follows: 100% modulation at 80 Hz, left channel, pilot on, 1k μ V output. Measure the distortion of each channel, switching the generator to give the same channel as the one being measured. Note that the left channel distortion pattern curves upward, and the right channel downward.

Return the first (L4) 19 kHz coil slug clockwise until the left channel output level is maximum, then fine-tune until the distortion patterns are nearly identical. Ignore the actual amount of distortion for the time being.

8. IF Filter Adjustment

Adjust trimmers C5 and C7 and, if necessary, the source (R5) and load (R6) resistors, to reduce the single-channel stereo distortion to less than 0.5%. Stereo distortion originating in the filter is caused by nonlinear phase shift, and adjustments involve solving three problems.

a. Position: The signal must be sent through the filter within a range of IF frequencies (centered approximately around the nominal 10.7 MHz) where the phase shift can be made most linear. As a general rule covering most filters, this frequency range can be found by tuning the tuner to display sharp spikes or discontinuities in the stereo distortion pattern, then tuning lower in frequency until the spikes just leave the display.

The zero-center tuning point chosen in Part II.B.2 will usually be nearly optimum for lowest stereo distortion, so it is best to try adjusting the trimmers and resistors first, before looking for a better IF frequency.

b. Phase Ripples: These are large, smooth bumps or dips in the distortion pattern, and can be cancelled by the trimmer adjustments. If the zero-center IF position has been properly chosen, the trimmers will have their greatest effect near the center of the pattern.

c. Band Width: The band width of the linear region is controlled by the source and load resistors. Increasing these resistors widens band width; decreasing them narrows it. It is preferable to increase the load resistor to widen band width, and decrease the source resistor to narrow it, since these choices reduce the insertion loss instead of increasing it.

The recommended range of resistors for each of the three IF filters can be found in Figure 6. Tuners having LC filters do not require any capacitive trimming.

9. Zero-Center Readjustment

If the best filter range is found to be different from the initial zero-center point, proceed as follows:

- Tune for lowest stereo distortion.
- Adjust the primary (top) slug of the discriminator for a zero-center reading on the tuning meter.
- Set the generator to mono (L+R, pilot off) modulation, and adjust secondary (bottom) slug for least distortion.

- Recheck sensitivity, readjusting the 10.7 MHz primary (top) slug for balanced noise.
- Recheck overload distortion.
- Recheck stereo distortion of 1k μ V input, and readjust trimmers to minimize it.

All of the above adjustments interact to some degree, and it may be necessary to repeat the above adjustment sequence several times. The goal is to coincide mono and stereo distortion, and best sensitivity, at the same tuning point. As the filter distortion is thus reduced, slight retuning of the first 19 kHz coil may be required to make the distortion patterns equal. Do not attempt to reduce stereo distortion by adjusting the bottom 10.7 MHz slug, even though it has some effect.

10. Final Multiplex Adjustments

a. Separation: Set the distortion analyzer for its voltmeter function. Monitor the tuner's left channel output while the generator is set for right-channel stereo modulation; then simultaneously reverse both monitor and generator channels, and monitor the right channel output. The generator should be set for 80 Hz modulation frequency. Adjust the balance pot (R58) for equally low outputs from each channel, ignoring the actual value. Then adjust the separation pot (R64) for minimum output of each. These pots interact, so repeat the adjustments a few times. Set the generator to 1 kHz, and make final balance and separation adjustments at this frequency. The patterns displayed indicate the residual distortions in the off-channels.

As long as the patterns have the same shape, the balance and separation adjustments are correct. If they are of slightly different amplitudes, within 2 db, this is an indication that the on-channel stereo distortions are slightly different.

Set the generator to 10 kHz modulation frequency, and check that the off-channels are at least 30 db below the on-channels. Adjust the SCA filter (L3) if necessary. Recheck the on-channel stereo distortion at 80 Hz, and slightly readjust the first 19 kHz coil for equal pattern shapes. Recheck the separation, but readjust only the separation pot if necessary.

The goal of these final adjustments is to have distortion and separation optimized at a single point. The tuner must have a minimum of 35 db of separation at 80 Hz, 40 db at 1 kHz, and 30 db at 10 kHz.

11. De-Emphasis Check

Measure the de-emphasis by comparing the relative audio output of each channel at 1 and 10 kHz, with respect to the 80 Hz level. Leave the generator and tuner controls as they were for the separation test. The on-channel response at 10 kHz should be 13.6 ± 0.5 db below the 80 Hz level, and the 1 kHz response 0.8 ± 0.5 db down. Be sure not to turn on the generator's pre-emphasis.

12. Pilot Dropout

This test assures good reception of weak stereo stations, and those whose pilot modulation may be less than the FCC-dictated 8% to 10%. Set the generator and

tuner to measure separation at 1 kHz, with 1k μ V signal level. Slowly reduce the pilot from 10% until the separation degrades to -35 db. The pilot level must be 6% or less; a carefully aligned tuner can achieve 1% to 3%.

13. Dial Calibration

Make sure the dial cord and drum are strung as shown in Figure 9. Turn the tuning knob clockwise until the drum stops; then move the pointer so that it covers the letter "S" in the word "Stereo." Make certain that the pointer is exactly parallel with the vertical tuning scale lines. Bend the pointer if necessary.

Tune to a station near 106 MHz, whose frequency is known, and adjust the oscillator trimmer until the station appears accurately on the dial. Tune to a station near 90 MHz and adjust the oscillator slug until calibrated. Recheck and readjust the first station's calibration. If enough stations of known frequency can be received, check their calibration. All stations between 90 and 106 MHz should be within 100 kHz (about one pointer's-width) of their allocation. If the end stations are exactly calibrated, but the calibration is low in between, move the pointer along the cord about 1/8" to the right, and repeat the calibration. If in-between stations are high, move the pointer to the left, and repeat the calibration.

14. Final Sensitivity Peaking

Set the generator and tuner as in Sweep Alignment, Part II.B.1. Observing the sweep pattern delivered by the detector probe, set the generator and tuner to an interference-free spot near 90 MHz. Adjust the antenna, RF amp, and mixer slugs for maximum gain. Retune to a spot near 106 MHz and repeat, except using the trimmer capacitors. Repeat the sequence until no further improvement in gain can be realized. With Görler front ends, the mixer adjustments tend to destroy the dial calibration. To compensate for this, carefully center the "nose" of the sweep pattern on the scope face. If the pattern shifts horizontally while peaking either the mixer slug or trimmer, restore the centering by using the oscillator slug or trimmer.

15. Interstation Hush and Stereo Squelch Adjustments

Before adjustment is attempted, make sure that the chokes L1, L2, and bypass capacitor C13 are positioned exactly as shown in Figure 7. This will greatly facilitate the smooth operation of these circuits.

Set the generator to 100 MHz and left or right channel stereo modulation at 1 kHz. Tune the tuner (using its zero-center meter) to the generator. The tuner must be in stereo mode, and the hush switch set to normal. Reduce the output to 7 μ V and adjust the stereo squelch pot (R33) causing the tuner to go into the mono mode. Reduce the output further to 3 μ V, and adjust the interstation hush pot (R23) so that the audio output is muted. Slowly reduce the generator output to 0.1 μ V, or as low as it will go, and observe that the audio remains muted for all signals below about 3 μ V. Slowly increase the output to 100k μ V, observing that:

- The audio reappears at about 3 μ V.
- The tuner remains in mono for all signals between 3 and 8 μ V.
- The tuner returns to the stereo mode, between 8 and 100k μ V.

16. Final Performance Check

Set the generator to mono, 80 Hz modulation, ± 75 kHz deviation, and $1\text{k } \mu\text{V}$ output at 90 MHz. Tune the tuner using the zero-center meter and measure:

- Mono THD = 0.25% or less at $1\text{k } \mu\text{V}$.
- Mono THD = 0.5% or less at $100\text{k } \mu\text{V}$.
- Sensitivity = $2 \mu\text{V}$ or better.

Retune the generator and tuner to 106 MHz and repeat THD and sensitivity measurements. The mono overload distortion is usually worse at 106 MHz; a slight readjustment of the 10.7 MHz secondary (top) slug may be necessary.

Retune generator and tuner to 98 MHz, and measure the above specs. Also measure:

- Stereo THD = 0.5% or less at $1\text{k } \mu\text{V}$.
- Stereo THD = 1% or less, between 100 and $100\text{k } \mu\text{V}$.
- Stereo separation @ $1\text{k } \mu\text{V}$:
 - 80 Hz = 35 db or better
 - 1 kHz = 40 db or better
 - 10 kHz = 30 db or better
- Proper operation of hush and squelch.

C. Modifications and Updates

1. Sensitivity Problems

Most problems can be attributed to regeneration in the IF amplifier and detector circuits. Examine the $0.01 \mu\text{F}$, $0.02 \mu\text{F}$, and $0.05 \mu\text{F}$ disk caps, which are used as bypasses. The lower portions of the cap bodies should be as close to the board as possible. If necessary, remove the caps from the board and scrape off any orange coating on the leads. Reinstall the caps. The cap which bypasses pin #10 of IC1 (C13, $0.02 \mu\text{F}$) should also be pushed over against the case of IC1. Both ICs and Q4 should be reinstalled with their leads as short as possible, especially IC1. Check the screws which secure the board and front end to the chassis. Route the 10.7 MHz lead which feeds the bandpass filter down along the side of the front end and close to the board. The DC power wiring should be dressed behind the front end, away from the IF lead.

2. Hush and Squelch Problems

If these circuits tend to operate below $2 \mu\text{V}$ input levels, or their pot settings are "touchy," then the IF is regenerative and/or the noise amps are oscillating. Perform all of the sensitivity modifications and, in addition, position the bandpass chokes (L1, L2) as shown in Figure 7. This reduces their inductive coupling and stabilizes the circuit. The hush and squelch pots must be reset if these chokes were not so positioned originally.

3. Stereo Squelch Update

In early tuners, the automatic mono-stereo switching (stereo squelch) was not defeatable; only the interstation hush circuit was. When receiving an over-modulated stereo station, these tuners tend to switch to mono during the modulation peaks, producing an annoying "thump." A modification was made, enabling the front-panel hush switch to defeat both hush and squelch.

The schematic diagram, Figure 6, incorporates this update. To update a tuner, connect an insulated wire 8" long, between the top of the squelch pot (R33) and the unused lug on the hush switch (S2-B). This terminal is directly above the lug which already has a wire connected to it. Also connect a bare wire between the center lugs of this switch; the lower lug is already connected to ground. Dress the new wire well away from the IF and detector circuits, on the foil side of the board. Add a 0.05 μ F disk ceramic capacitor between base and collector of Q12 (2N4248).

The tuner will now remain in stereo between stations. This slight annoyance is much less disturbing than the "thumping" into mono which occurs during over-modulated stereo reception.

4. De-Emphasis Update

Change R88 and R89 from 8k2 to 6k8.

FIGURE 6
TUNER SCHEMATIC

IF FILTER OPTIONS

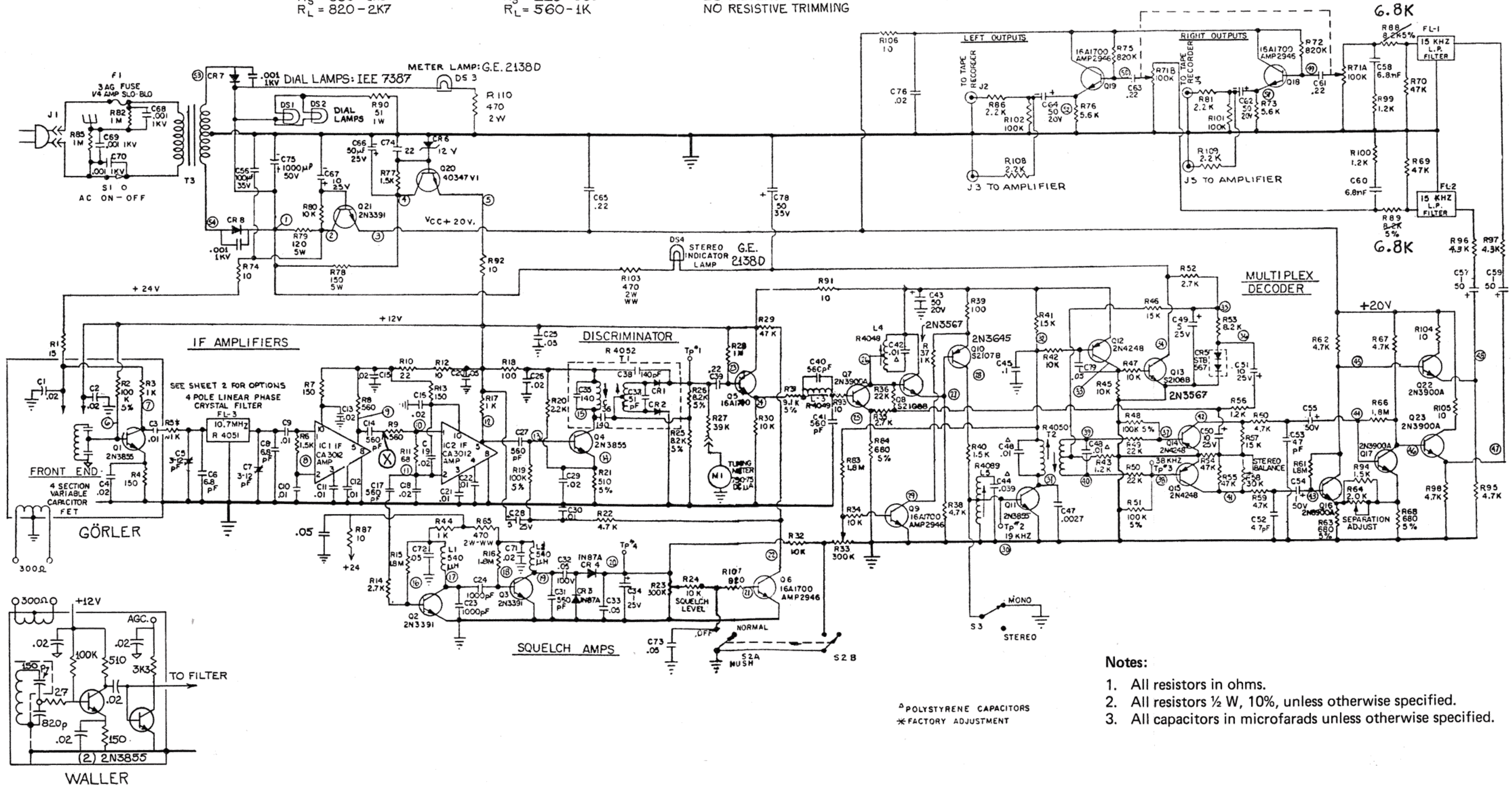
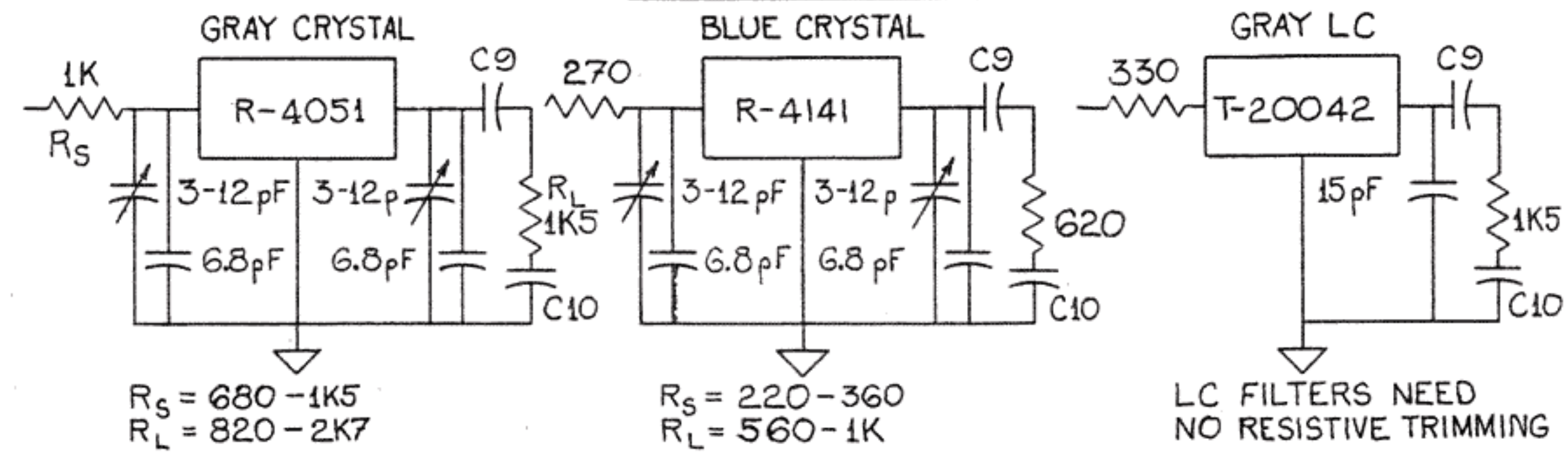

Notes:

1. All resistors in ohms.
2. All resistors 1/2 W, 10%, unless otherwise specified.
3. All capacitors in microfarads unless otherwise specified.

^a POLYSTYRENE CAPACITORS
* FACTORY ADJUSTMENT

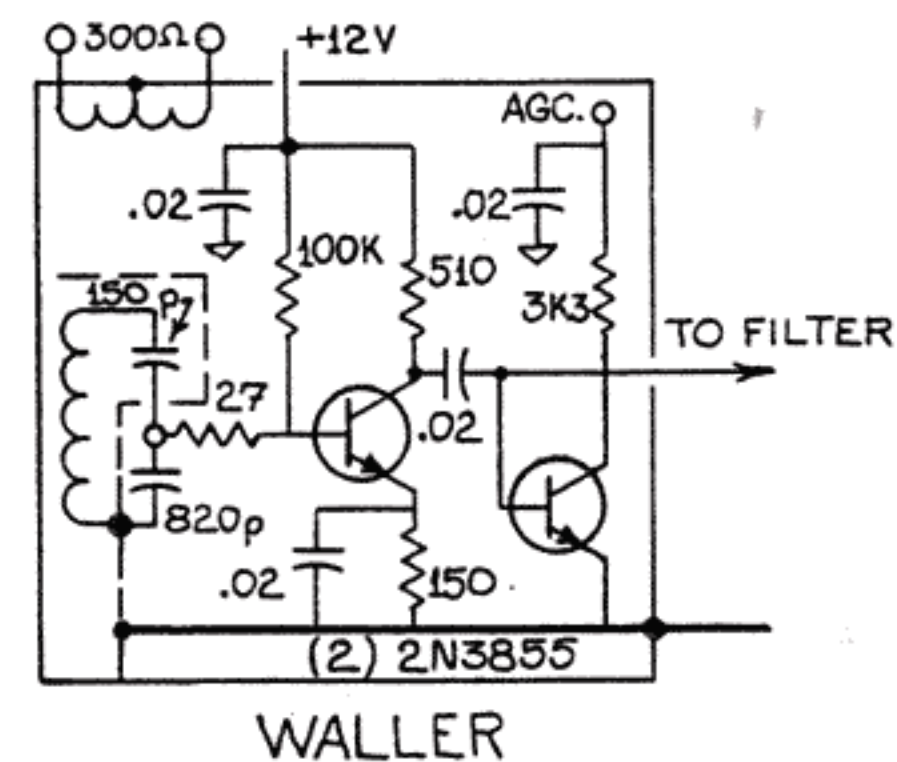

FIGURE 7
TUNER BOARD

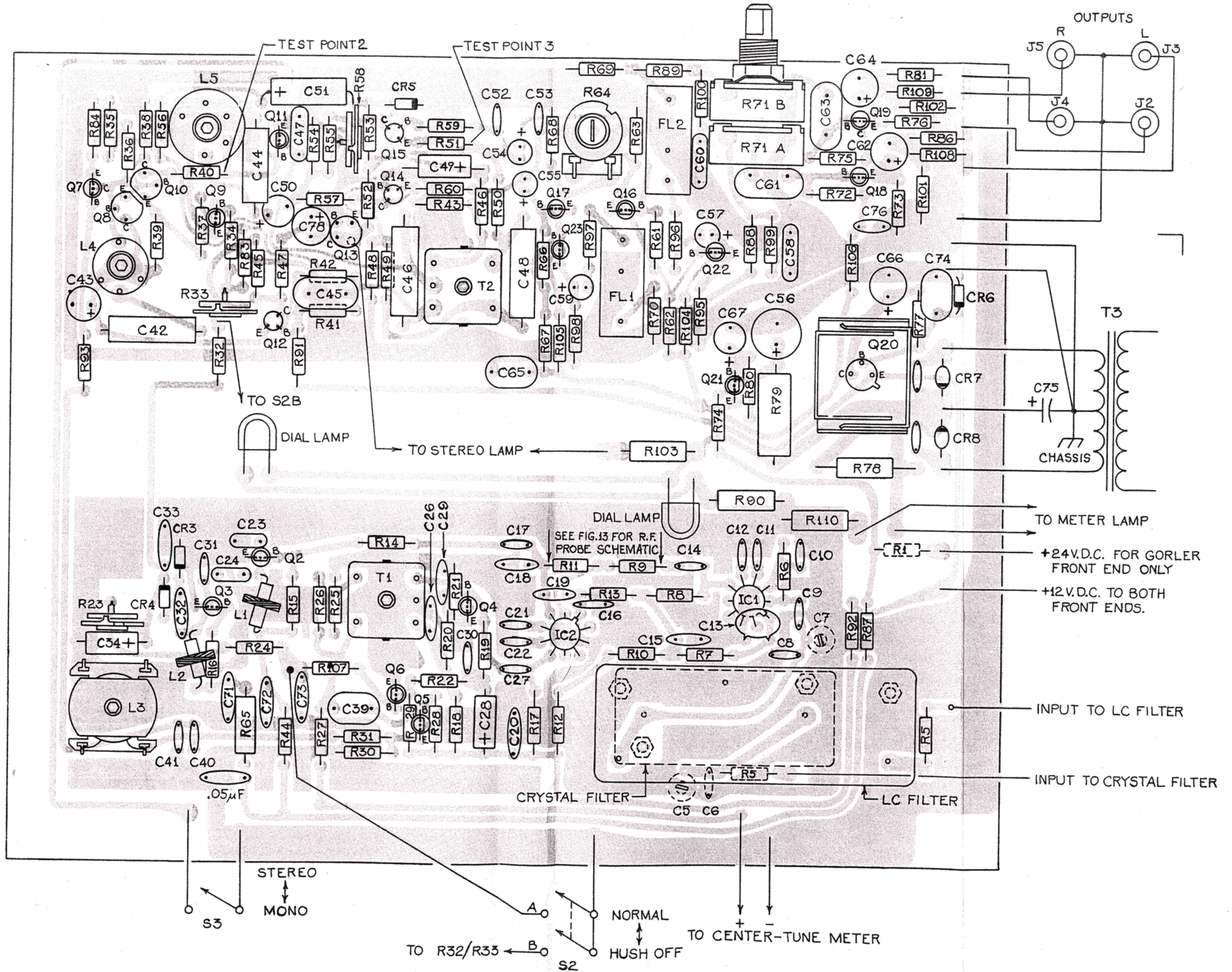
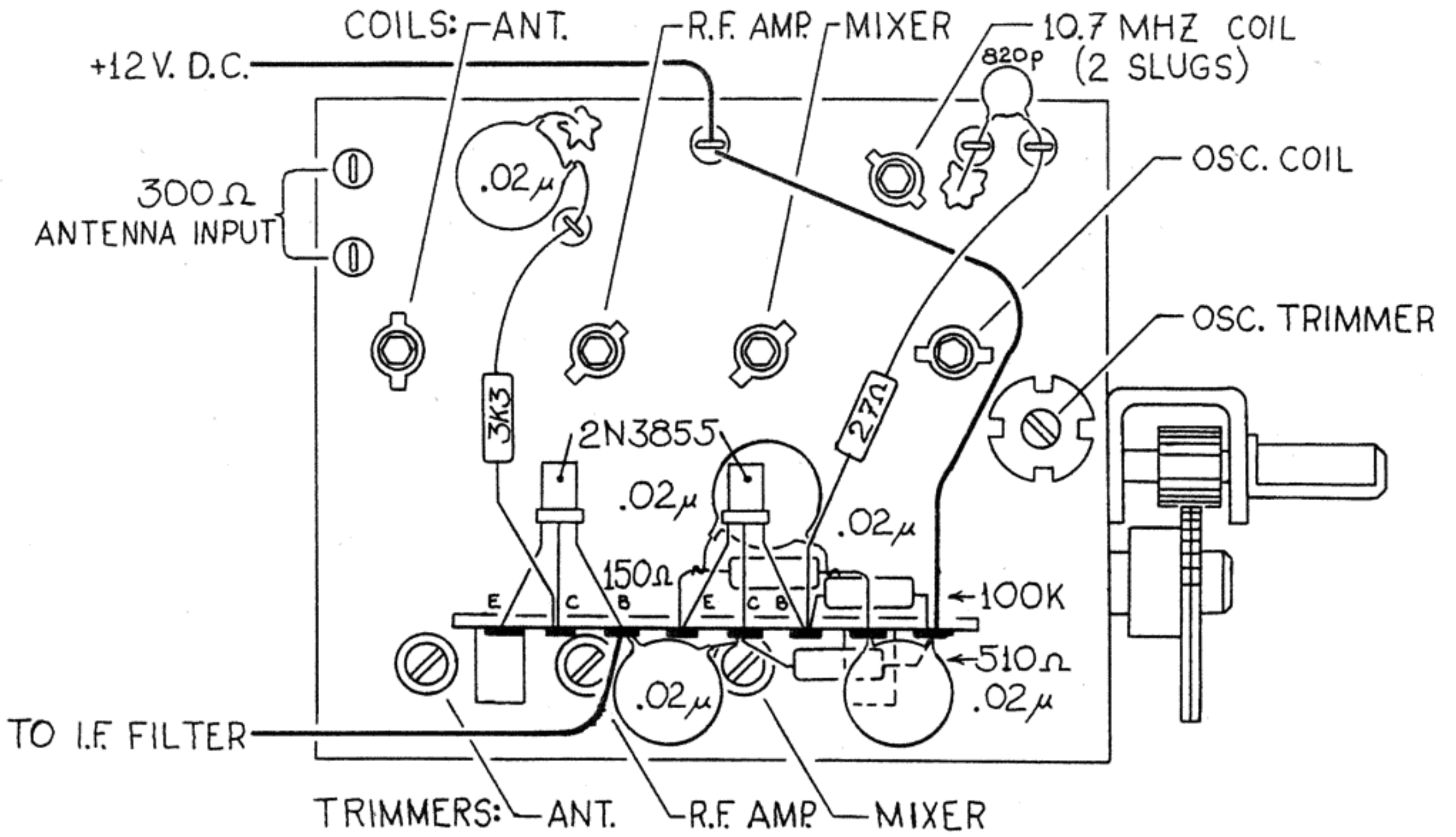
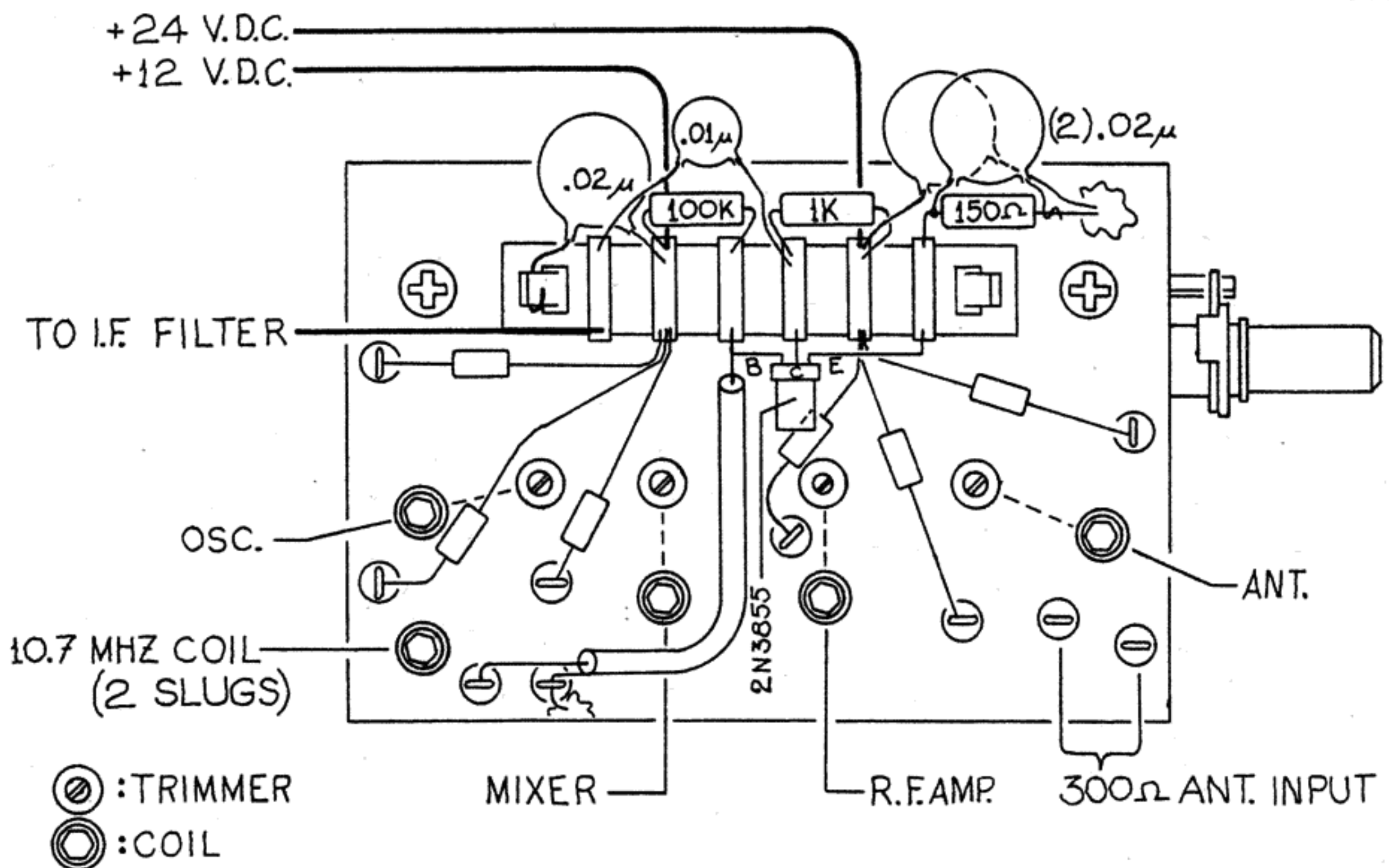

FIGURE 8
FRONT ENDS

WALLER



GÖRLER



D. Dial Stringing Instructions

The Görler and Waller front end external shafts rotate in opposite directions for the same tuning knob rotation. Therefore, two dial stringing procedures are illustrated in Figure 9.

Before stringing, it is a good idea to clean the entire dial cord path: the drum, the pulleys, and especially the flywheel shaft. Also remove any dust or grease in the general area of the flywheel. This will assure positive, non-slip tuning.

Form a knotted loop in one end of the cord and thread the cord as described below. After following step 1 or 2 below, hook the spring onto lug 2 and pass the cord through the spring's other end. Pull on the cord so that the spring extends about 1/16", and tie the cord to the spring. To eliminate the spring turns from rubbing on the drum, install a short length of heat-shrink tubing over the spring, leaving the ends exposed.

1. Görler

Facing the front end shaft, rotate it fully clockwise, and orient the drum as shown. Slip the dial cord's knotted loop over Lug 1 of the drum, and wind the cord two full turns counter-clockwise around the drum. The turns should advance towards the front end. Then thread it around pulleys A, B, and C, and wrap 3 turns around the flywheel shaft groove. The cord must enter and leave the groove under the shaft. Pass the cord around pulley D; then wind it one-half turn clockwise around the drum, in front of the previous windings. Hook the spring over lug 2. Above the 108 MHz marking on the dial, twist the cord so that the top side moves back. Hook the pointer onto the cord, and slide it to the right, stopping over the letter "S" in the word "Stereo."

2. Waller

Facing the front end shaft, rotate it fully counter-clockwise. The drum orientation should be as shown. If not, remove the drum, loosen the two screws attaching the drive gear, and reposition the shaft. The gear which turns the tuning gang is a spring-loaded split type, to eliminate backlash. Make sure that this spring is compressed before remounting the drive gear. Before tightening the screws, push the drive gear against the split gear as far as it will go, then back off slightly.

Slip the dial cord's knotted end over lug 1 of the drum, then directly out around pulley A, and wind 3 turns around the flywheel shaft groove. The cord must enter and leave the groove under the shaft. Proceed threading around pulleys B, C, and D. Make almost one complete counter-clockwise turn around the drum, passing behind the starting end of the cord where it left the drum. Pass the cord in front of the cord section which is past pulley D, and wind one-half turn more, through the pulley rim, and hook the spring over lug 2. Attach the pointer as described in the Görler section.

3. Final Adjustments

Tune the tuner in each direction and listen for mechanical noises, especially the cord turns on the drum snapping over each other. The cord may have to be laterally adjusted where it enters the drum opening. If the tuning slips, readjust the cord length by tying knots near either end. For the Waller units only, tension can be varied by bending the support for pulley A.

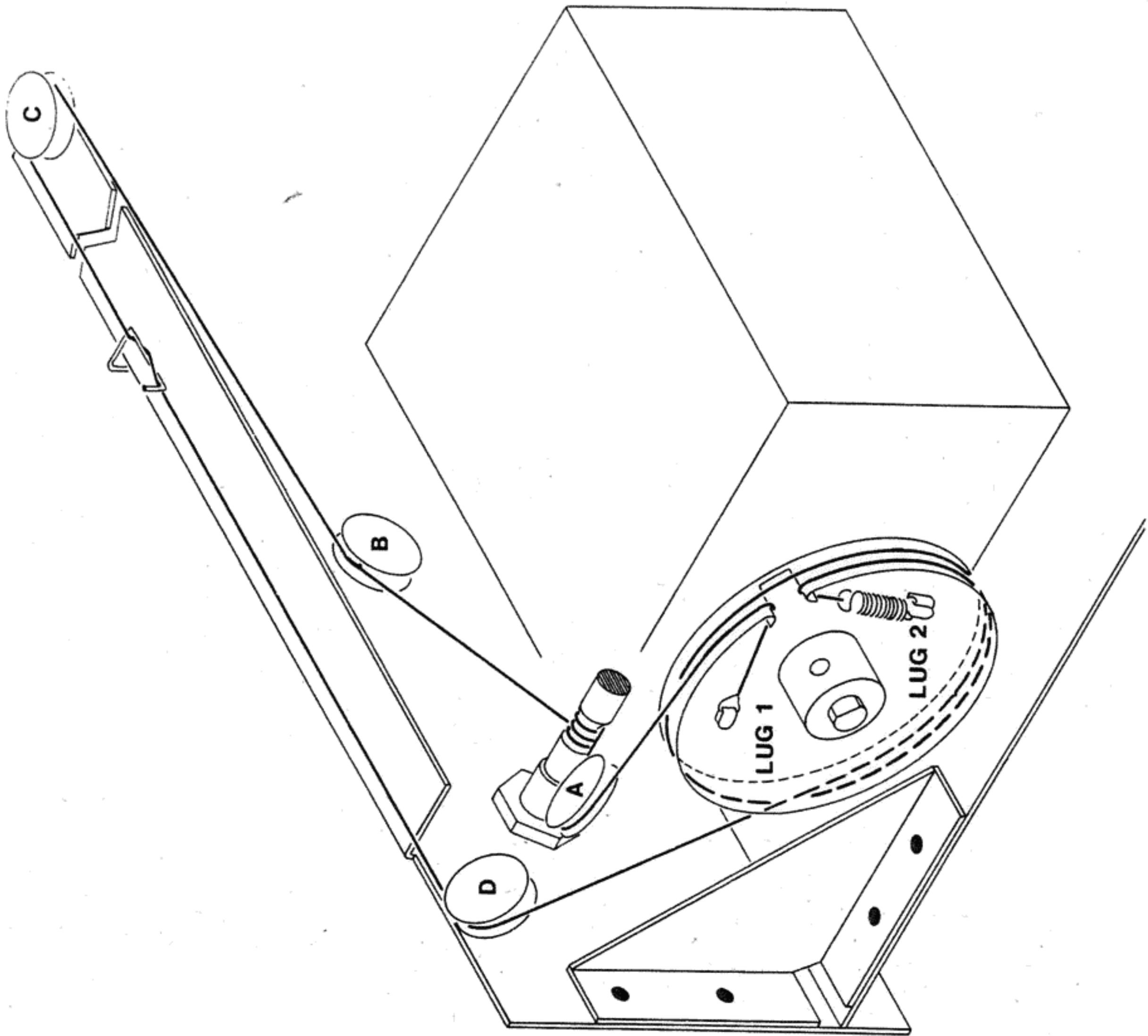
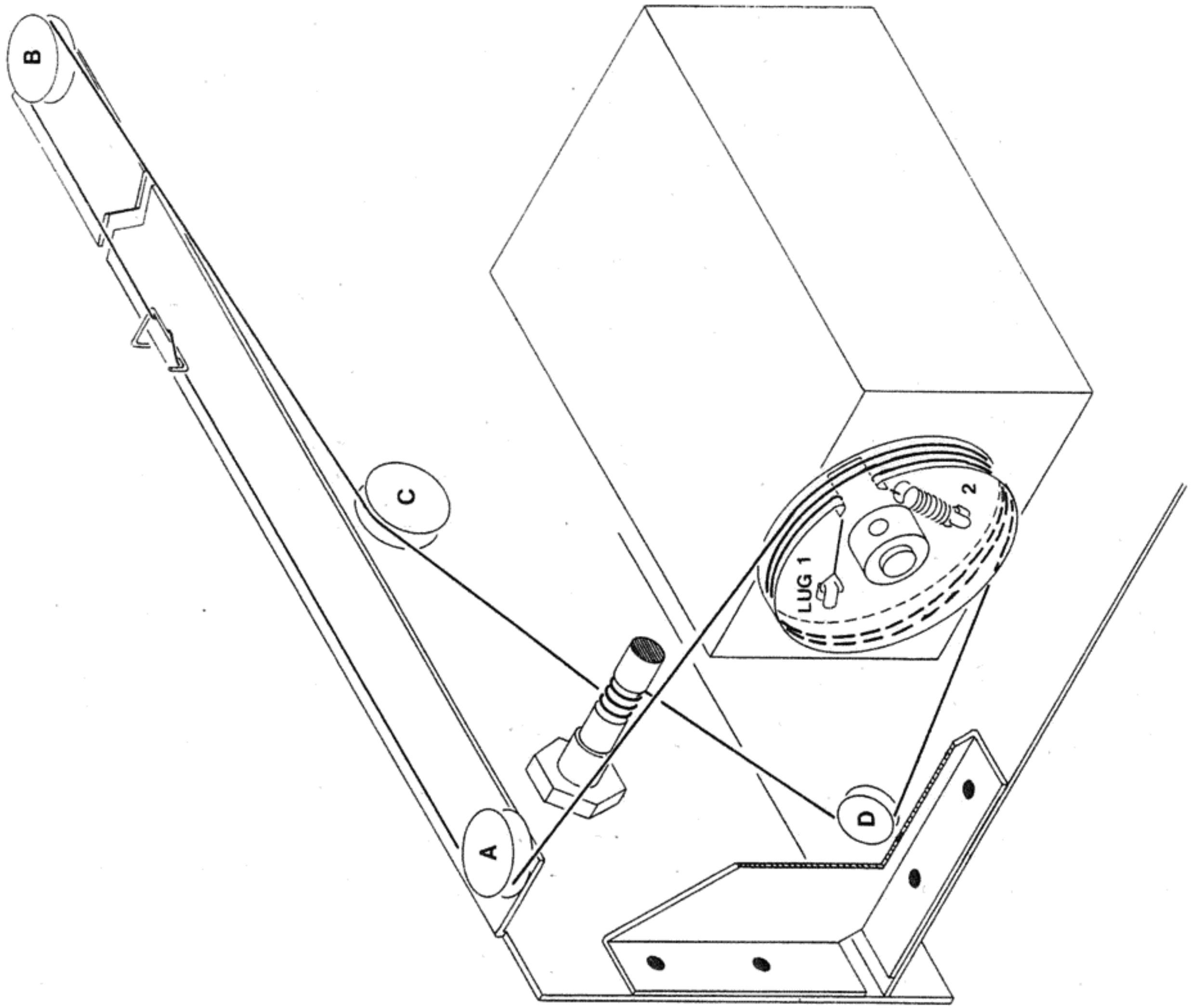

FIGURE 9
DIAL CORD STRINGING

GÖRLER

WALLER

E. Specifications

- Sensitivity:
2.0 μ V or better, for 30 db of quieting (IHFM)
- Signal to Noise Ratio:
65 db (ASA "C" weighting)
- Distortion:
IM and THD = 0.25% or less, mono
IM and THD = 0.50% or less, stereo
- Frequency Response:
20 Hz to 15 kHz, \pm 1 db, mono and stereo
- Capture Ratio:
2.0 db or less
- Selectivity:
55 db or better (alternate-channel)
- AM Suppression:
55 db or better
- Spurious Responses:

Image rejection:	70 db or better
IF rejection:	100 db or better
Other responses:	90 db or better
- Separation:
35 db minimum at 50 Hz
40 db minimum at 1 kHz
30 db minimum at 10 kHz
- Output Level:
750 mV RMS minimum for 100% modulation, at maximum setting of level control
- Output Impedance:
Less than 1k ohm; will drive loads of 10k ohms or higher

III. RECEIVER

A. Description

The receiver is essentially the amplifier and tuner in one package. All of the circuitry and adjustment procedures used for servicing the separate components can be applied to a receiver. Follow the text and figures in sections I and II, and read this section for additional information. The specifications are the same.

All circuit part numbers (i.e., R23, C46, etc.) in the text of sections I and II, refer specifically to those schematics. Notice that these numbers don't always coincide with the receiver schematic numbers (Figure 10), even though the electrical values and circuit connections are identical. However, on the board layouts in this section, which are all unique to the receiver, the numbers match the schematic.

1. Amplifier Section

a. Phono Preamp: The receiver's board is identical, except that the gain pot has a single shaft and knob, instead of dual concentric shafts and knobs.

b. Tone Control: The board is identical, except that the mode switch has additional contacts which connect to the multiplex board. These contacts put the multiplex into the mono mode when the mode switch is set for mono or null.

c. Power Amplifier: All components are mounted on two boards attached to the heat sinks, instead of the point-to-point wiring of the amp. (See Figure 11.)

d. Power Supply: All small components are on a board, instead of the point-to-point wiring of the amp. (See Figure 12.)

2. Tuner Section

The receiver has separate IF and multiplex boards in place of the tuner's single board.

a. IF Board: There are no RC decoupling components in the +20 V DC feed to the noise amps. Receivers having the LC IF filter are provided with a bracket for mounting this to the front end. (See Figure 13.)

b. Multiplex Board: The multiplex filters in the receiver are RC 38 kHz notch types, instead of the LC low-pass types used in the tuner, and have no emitter-follower buffers after them. (See Figure 14.) The resulting higher source impedance causes early production receivers to be easily loaded down by most tape recorder inputs. Later receivers are equipped with tape output boards having low output impedance. This board also provides switchable de-emphasis for universal receivers. (See Figure 15.)

3. Input Selector Switch

The receiver's switch has additional contacts which dim the meter lamp and short the input to IC2, when sources other than FM are selected.

4. Additional Features

The receiver incorporates a headphone jack, speaker-headphone switch, and derived center-channel (mono) output jack.

B. Modifications and Updates

1. Amplifier Section

All of the data given for the amplifier apply to the receiver. For specific details of the bias update, refer to Figure 11.

2. Tuner Section

All of the data given for the tuner apply, plus the following sensitivity modifications:

- Twist the tuning meter leads together, and dress them above the tone board.
- The black stereo lamp lead should also be dressed above the tone board and beside the meter leads.
- Install an additional $0.02\mu\text{F}$ cap across C21, grounding it directly to the lug which attaches to the discriminator shield. Use the shortest possible lead length, and orient it perpendicular to the board.
- Locate the pink wire connecting the hush switch to the base of Q6 (on the IF board) and add a resistor between 820 ohms and 1k5 in series with this wire. Position the resistor perpendicular to the board.
- Locate the pink wire which connects to pin #2 of IC2 on the IF board, and position it perpendicular to the board.

The above procedures should cure most sensitivity problems, but the next two steps should be done if the problem persists.

- Add a 1k resistor in series with the tuning meter, positioning it perpendicular to the board.
- Add a 1k5 resistor in series with the coupling capacitor (C30, $0.22\mu\text{F}$) which feeds Q5.

FIGURE 10
RECEIVER SCHEMATIC

NOTES:

1. All resistors 1/2 W, 10% unless otherwise specified.
2. All capacitors in microfarads unless otherwise specified.
3. S-2 = Selector Switch: A = Phono, B = FM, C = Special
4. * R4, R105, R106, R123, R124, R153, and R171 resistors are nominal values to be determined for each unit.

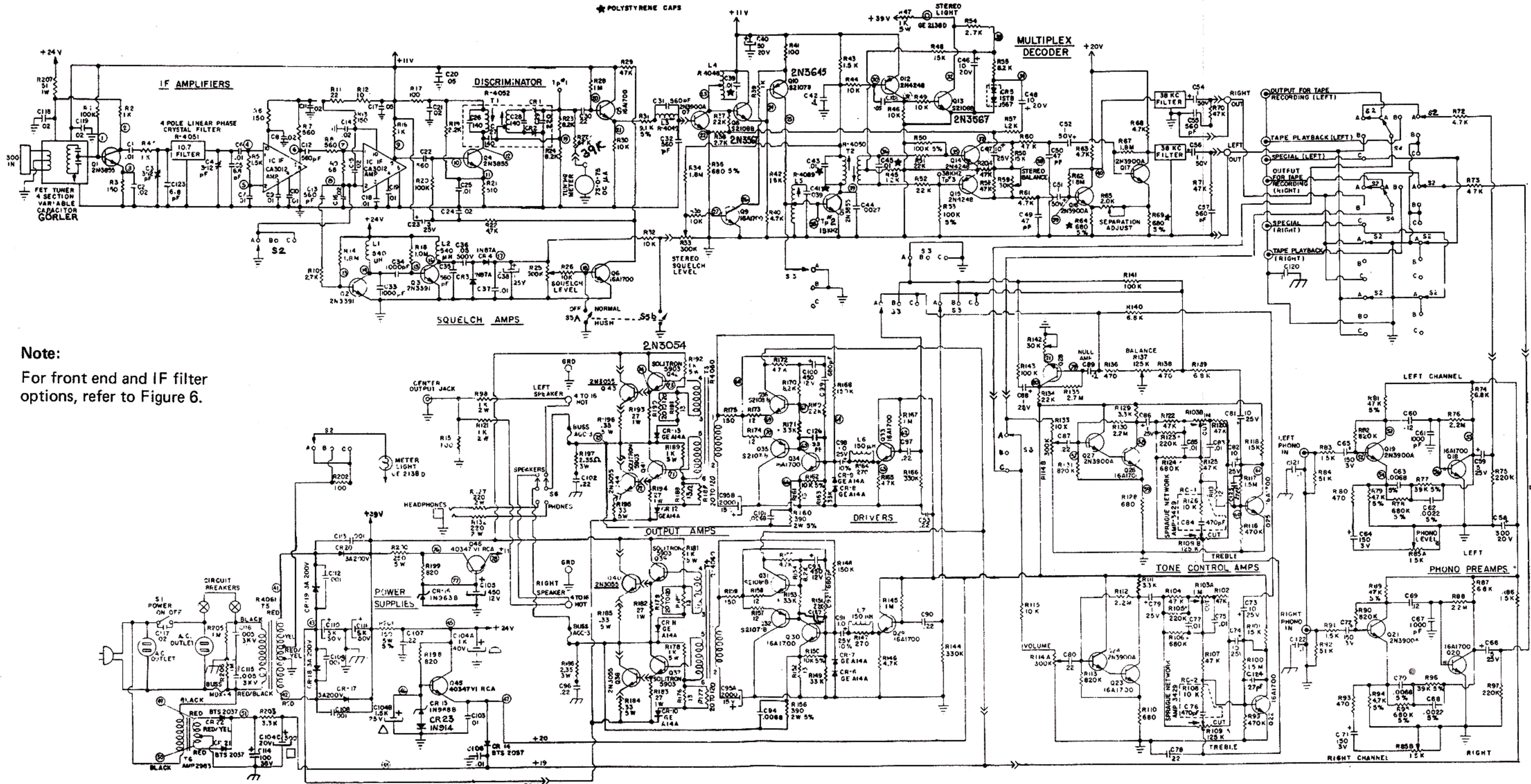

Note:
For front end and IF filter options, refer to Figure 6.

FIGURE 11
POWER AMPLIFIER BOARD

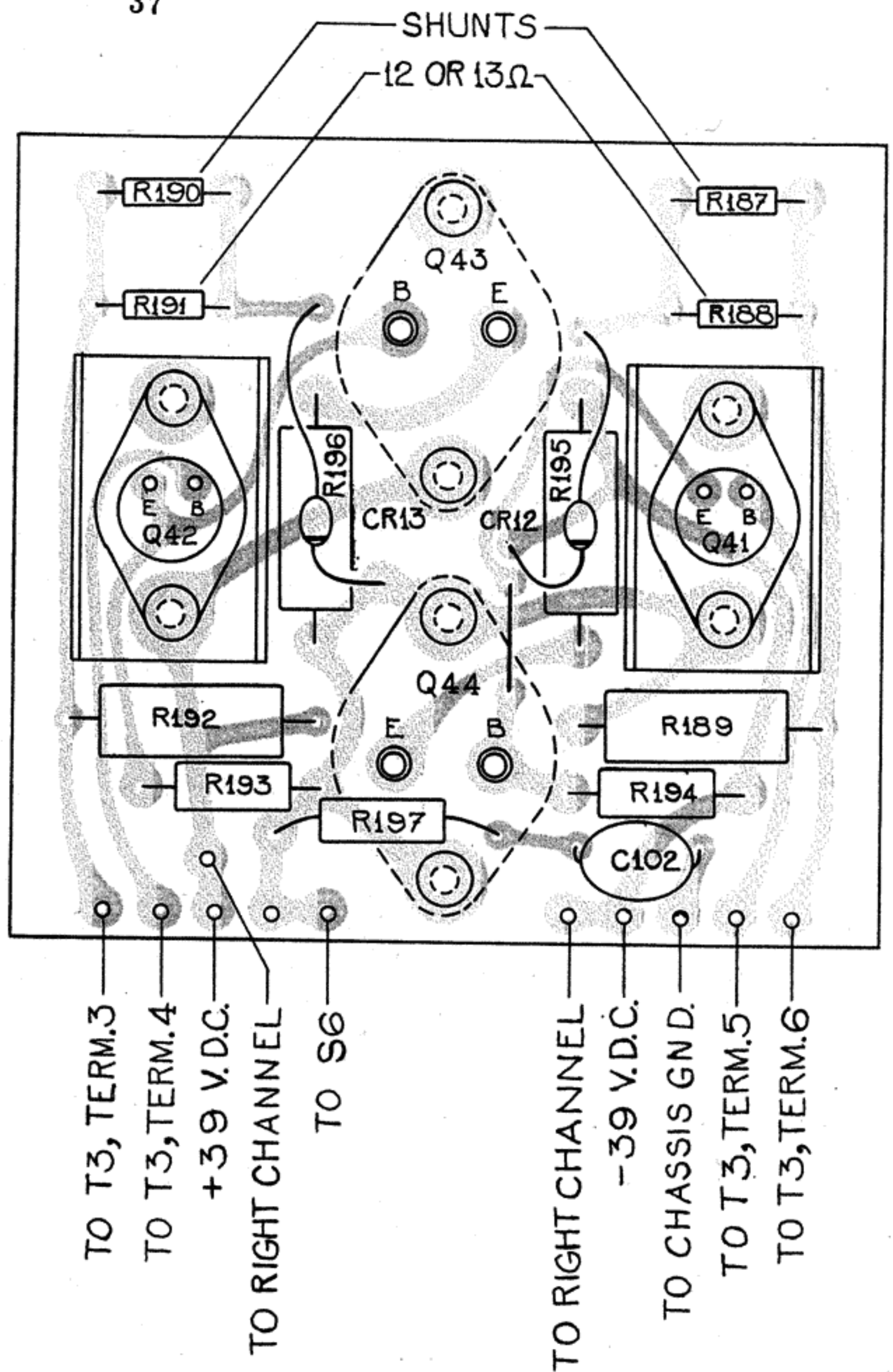

BIASING UPDATE FOR
BOARDS WITH POTS

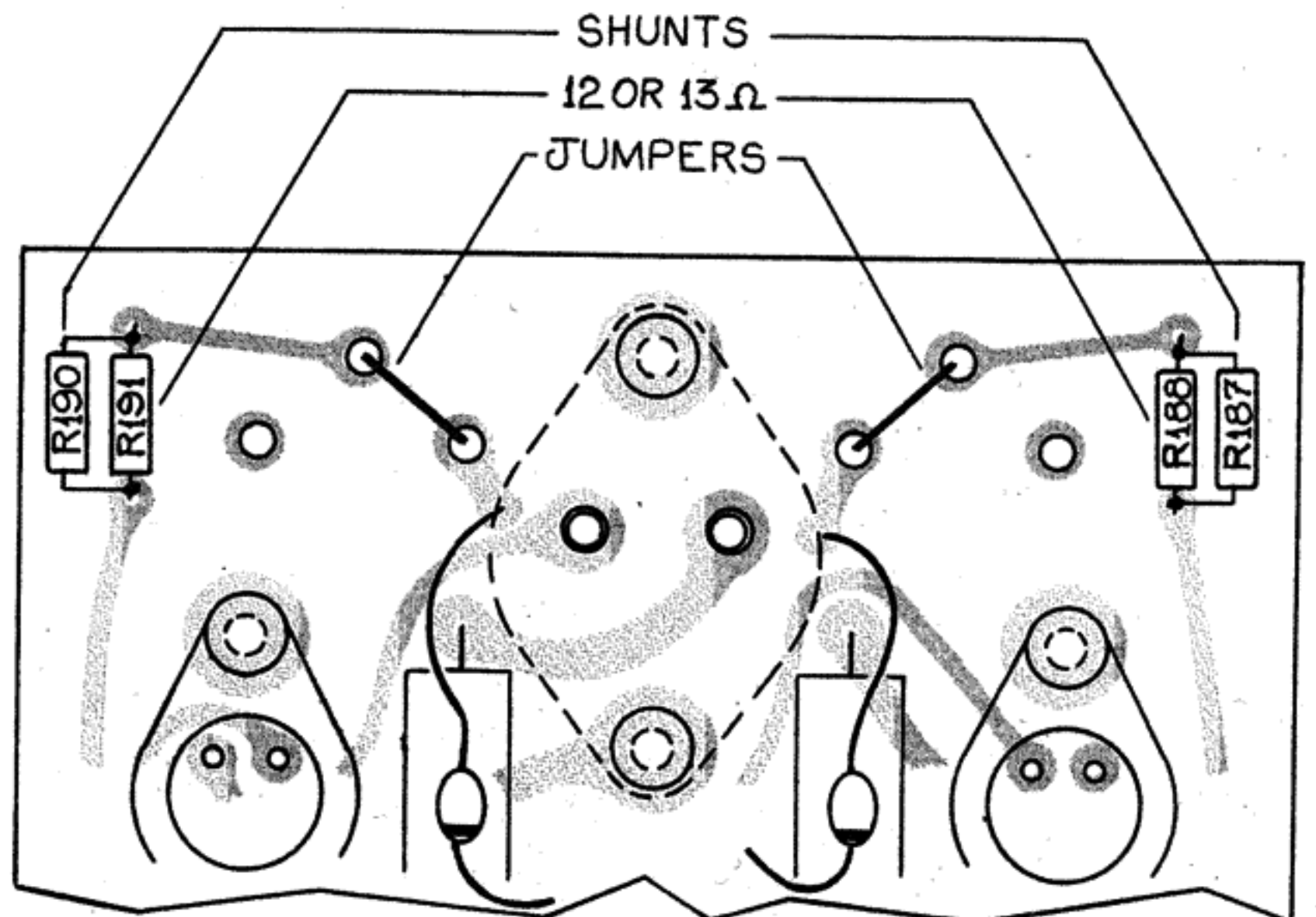

FIGURE 12
POWER SUPPLY BOARD

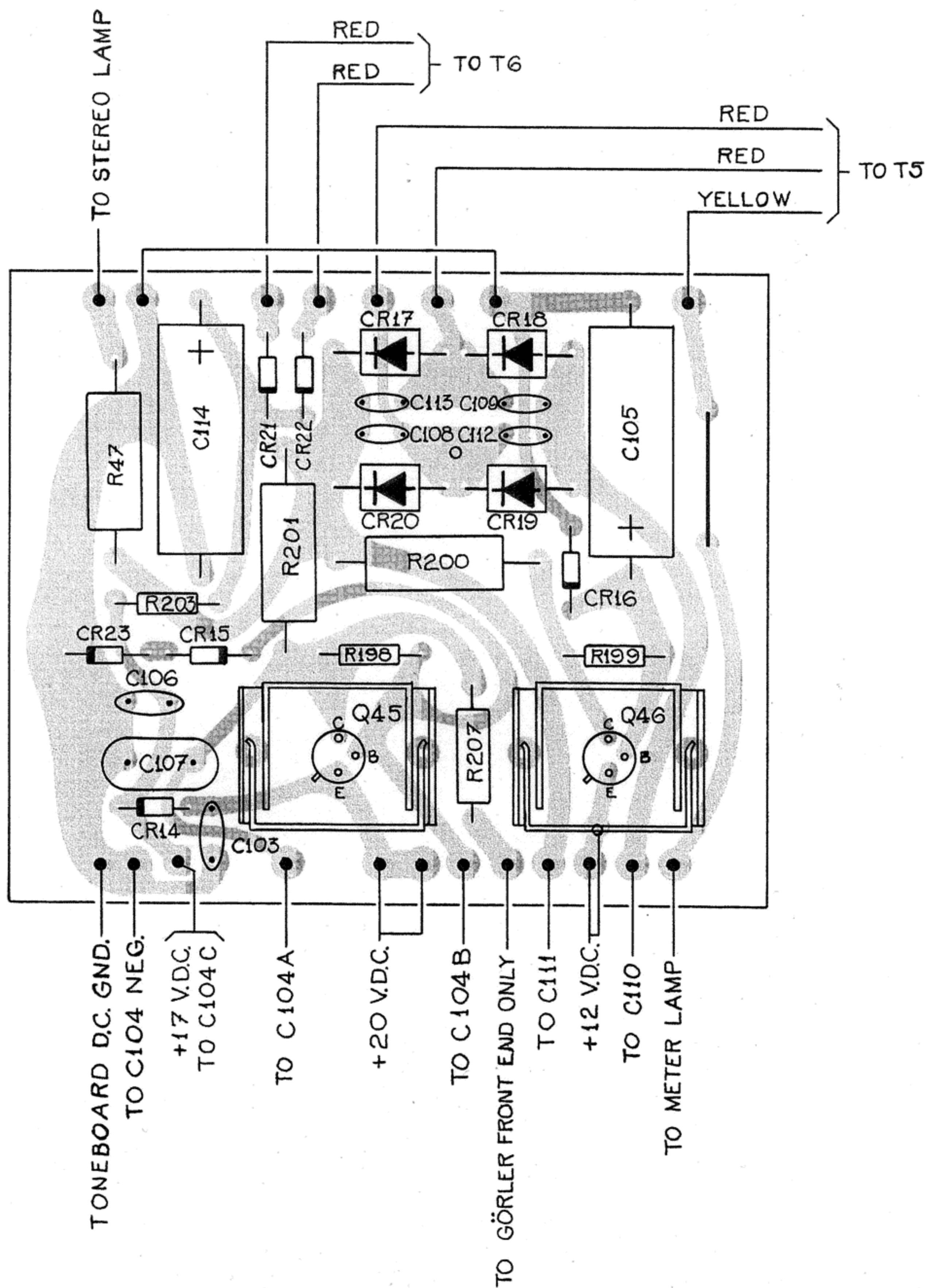

FIGURE 13
IF BOARD

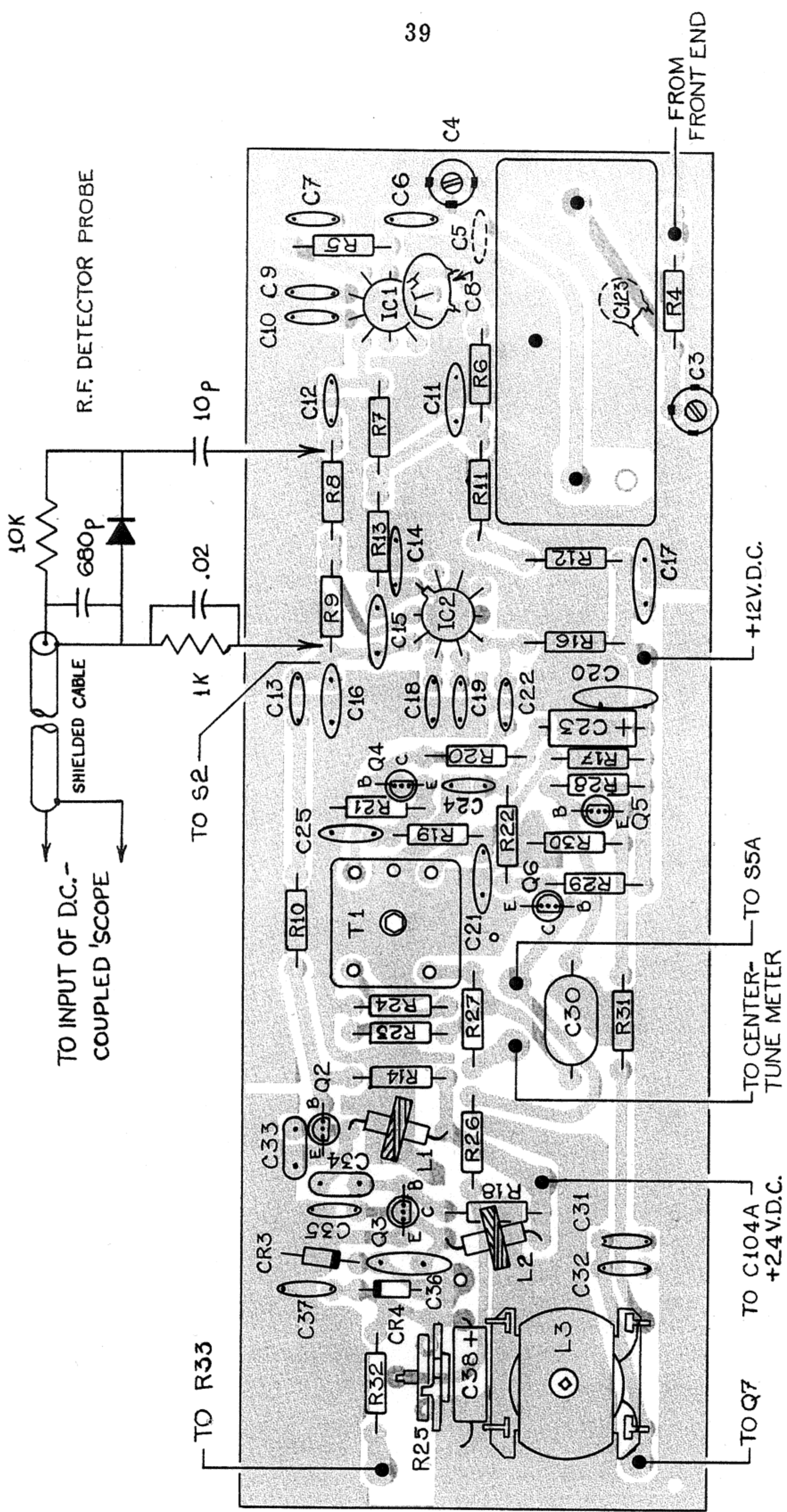

FIGURE 14
MULTIPLEX BOARD

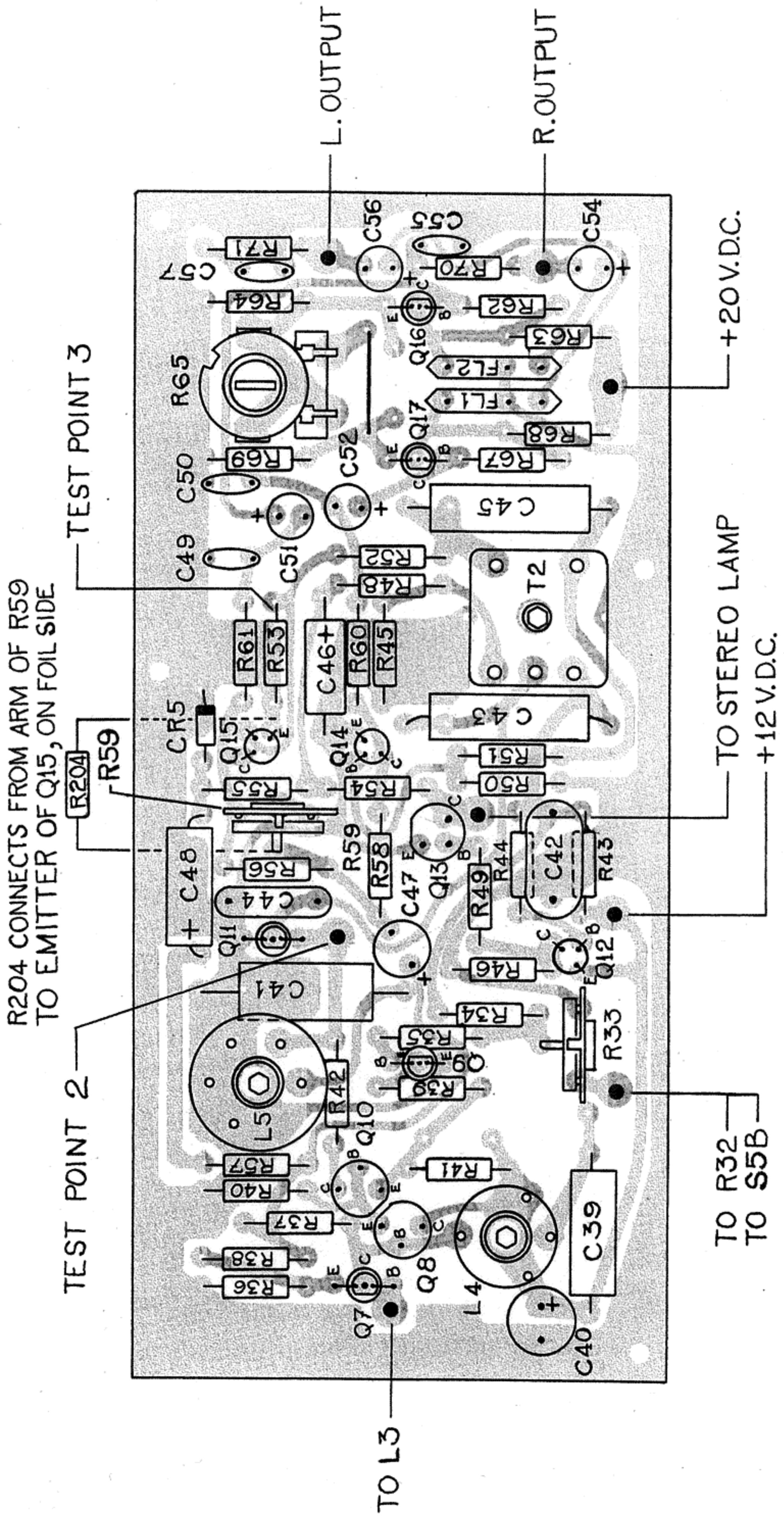

FIGURE 15
TAPE OUTPUT BOARD

Note:

For domestic receivers, C55 and C57 are installed, and C136 through C139 are omitted.

For universal receivers, C136 through C139 are installed, and C55 and C57 are omitted.

Switch shown in 50 μ sec position.

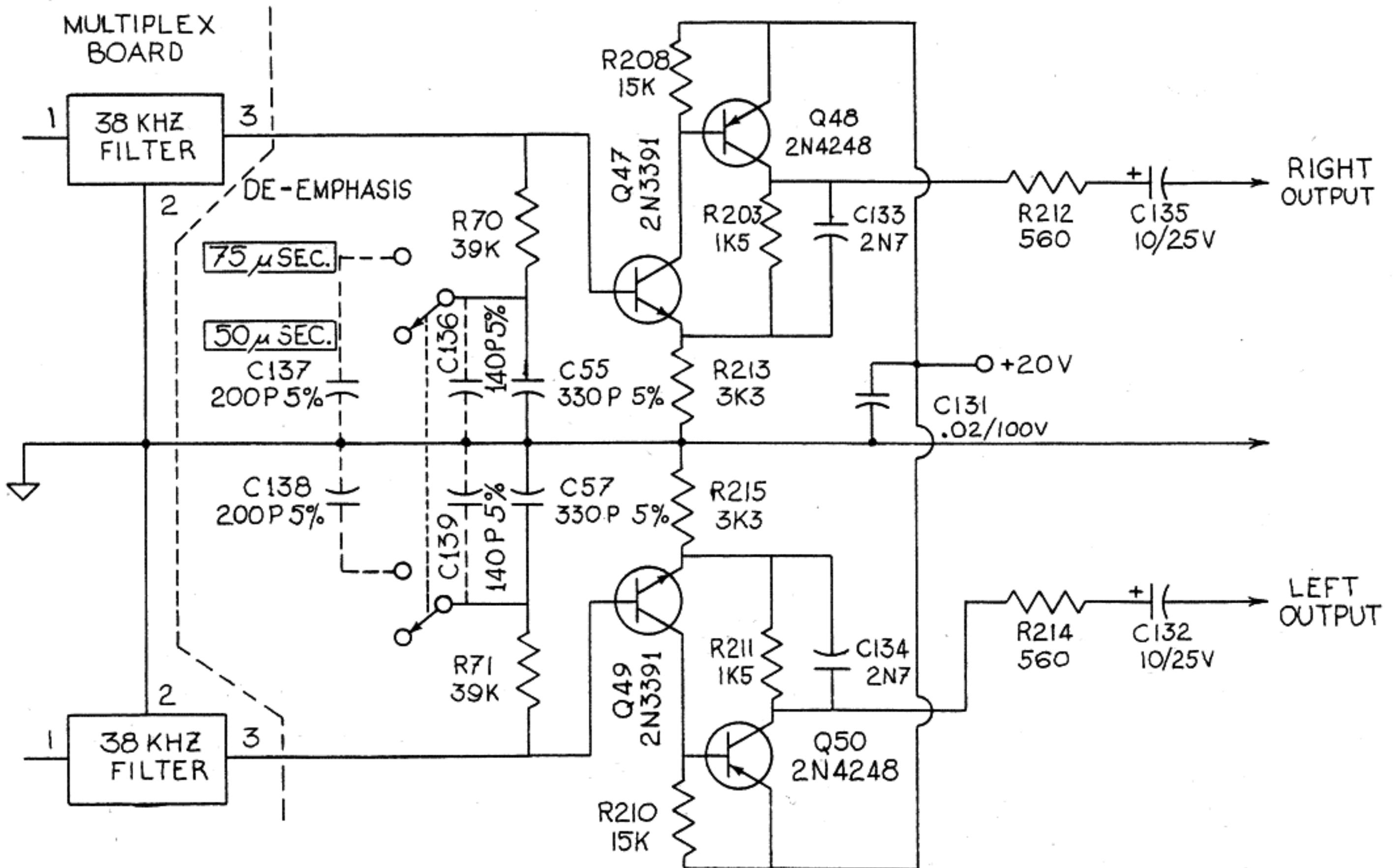
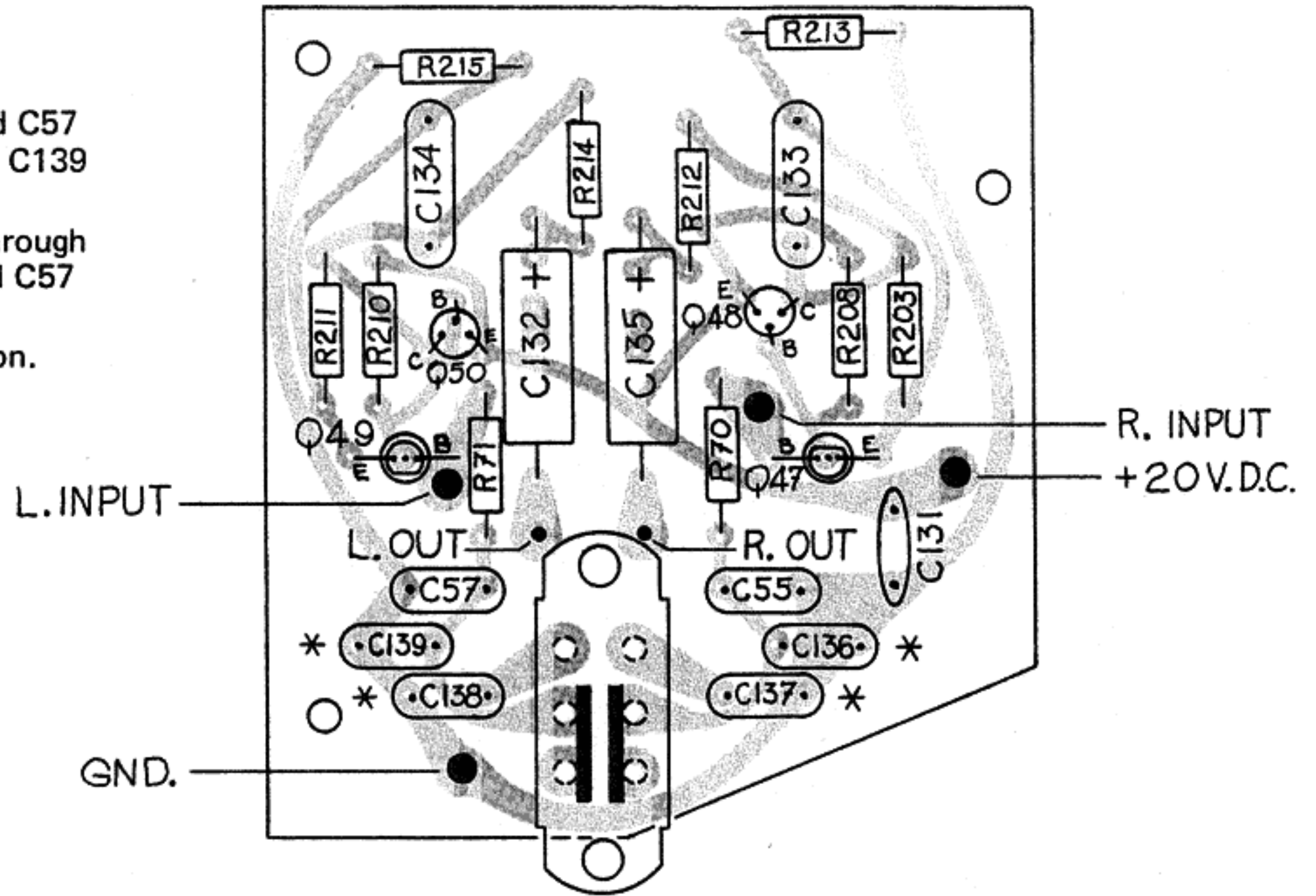

IV. UNIVERSAL MODELS

These are units which operate on 240 V AC or 120 V AC. In the tuner and receiver, the voltage can be selected with a slide switch, but the amplifier must be rewired. The FM de-emphasis can be changed from 75 μ sec (used in the U.S. and Canada) to 50 μ sec (used elsewhere) with slide switches. Refer to Figures 15 through 20 for specific details of each unit.

V. TEST EQUIPMENT

The first listings in each category are the models used to produce the AR components. Since most of these models are no longer produced, suggested alternates are listed.

Harmonic Distortion Analyzer

Hewlett-Packard 331, 333
Heath IM-5258
Sound Technology 1700, 1710

Intermodulation Distortion Analyzer

Measurements 940
Crown IMA
Heath IM-5248
Sound Technology 1700, 1710,
with 004 option

Oscillator, Sinewave

Heath IG-18
Heath IG-5218
Heath IG-1272
Sound Technology 1400A

Oscilloscope

Tektronix 503
Any scope having vertical sensitivity of 2 mv/cm or better, bandwidth of at least 500 kHz, and external horizontal input.

Stereo Generator

Radiometer SMG1C

FM Generator

Measurements 188

FM Stereo Generator

Sound Technology 1000A

FIGURE 16
AMPLIFIER TRANSFORMER WIRING

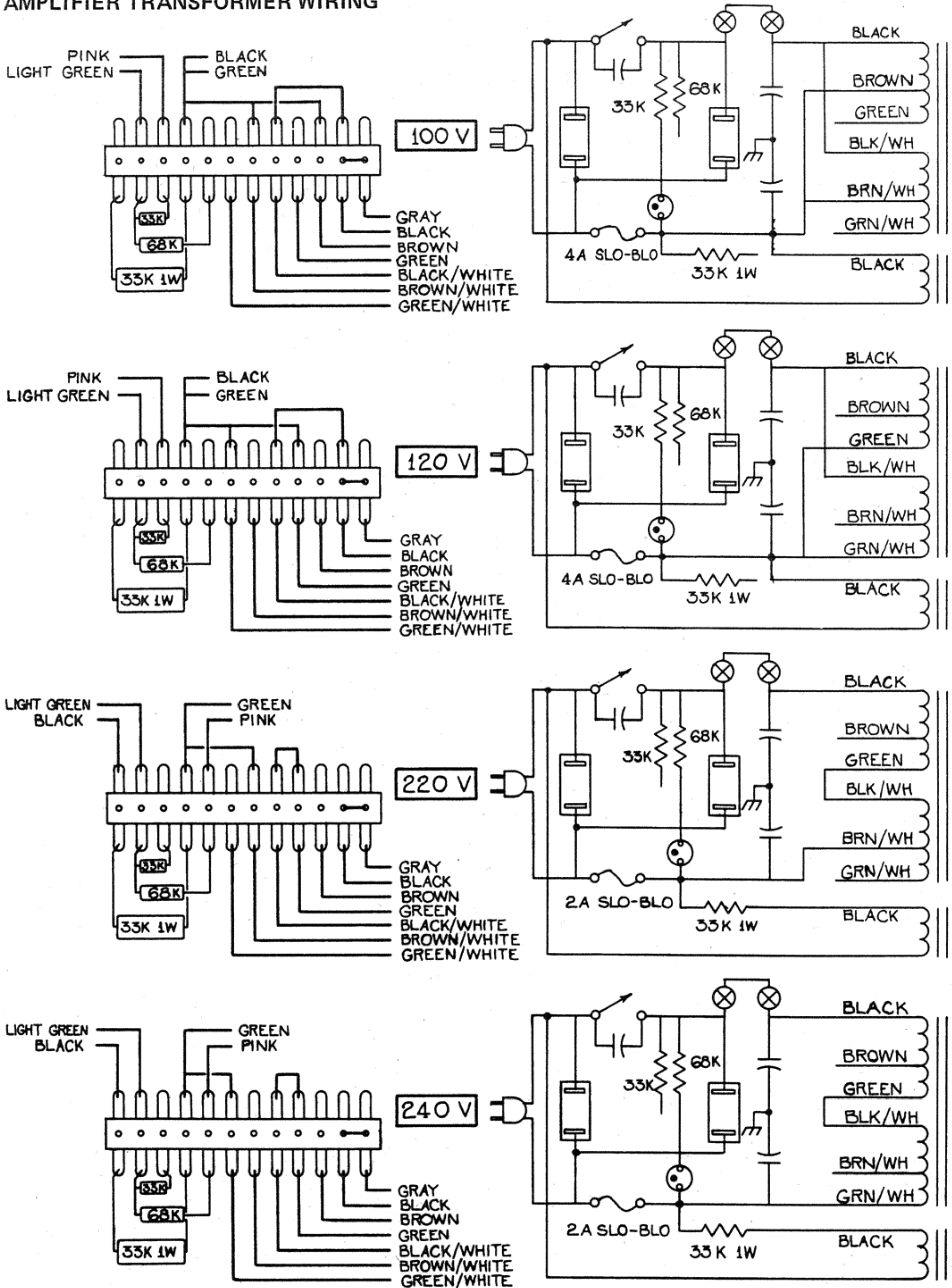

**FIGURE 17
RECEIVER TRANSFORMER WIRING**

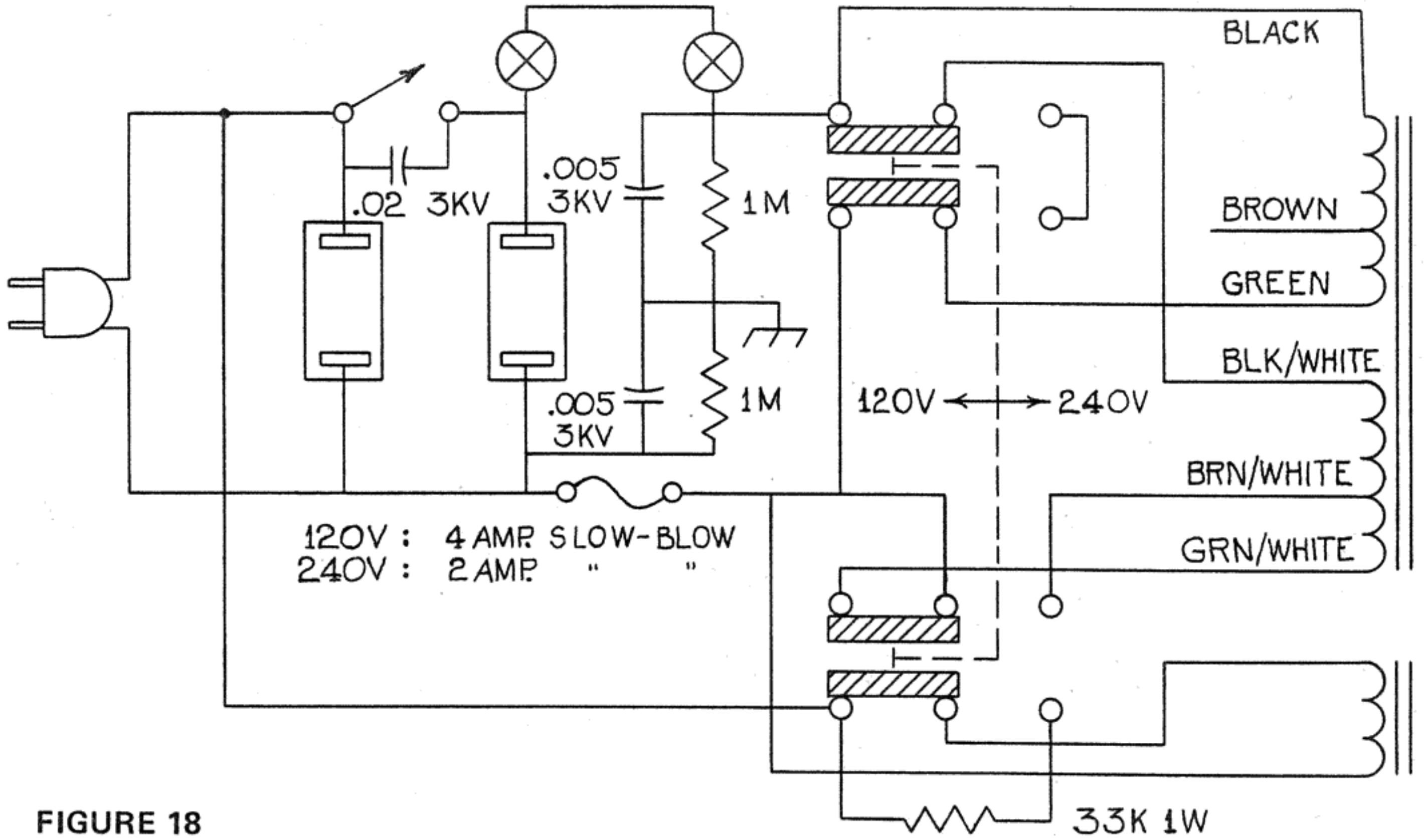

**FIGURE 18
RECEIVER FM DE-EMPHASIS FOR UNITS
WITHOUT TAPE OUTPUT BOARDS**

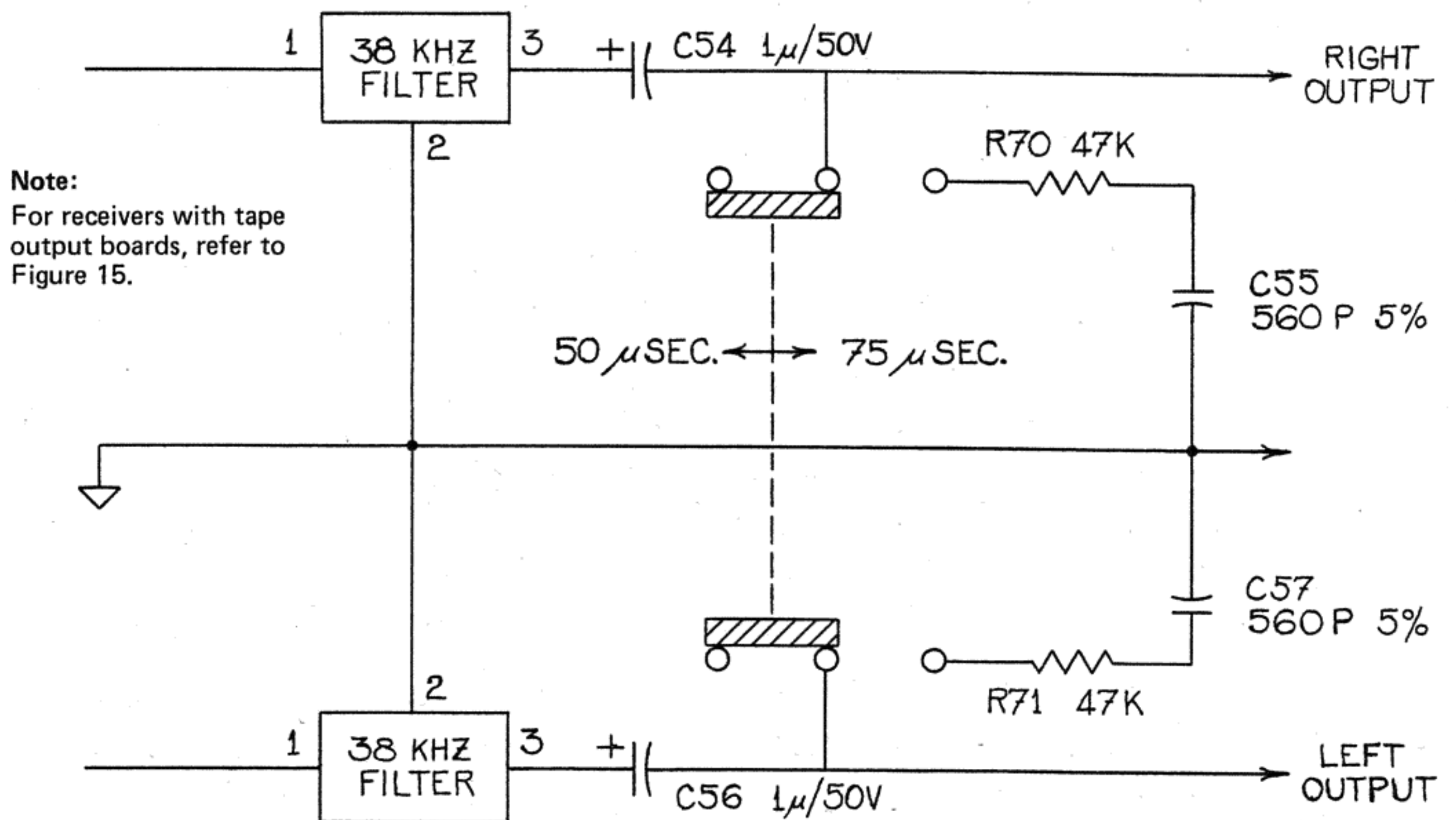

**FIGURE 19
TUNER TRANSFORMER WIRING**

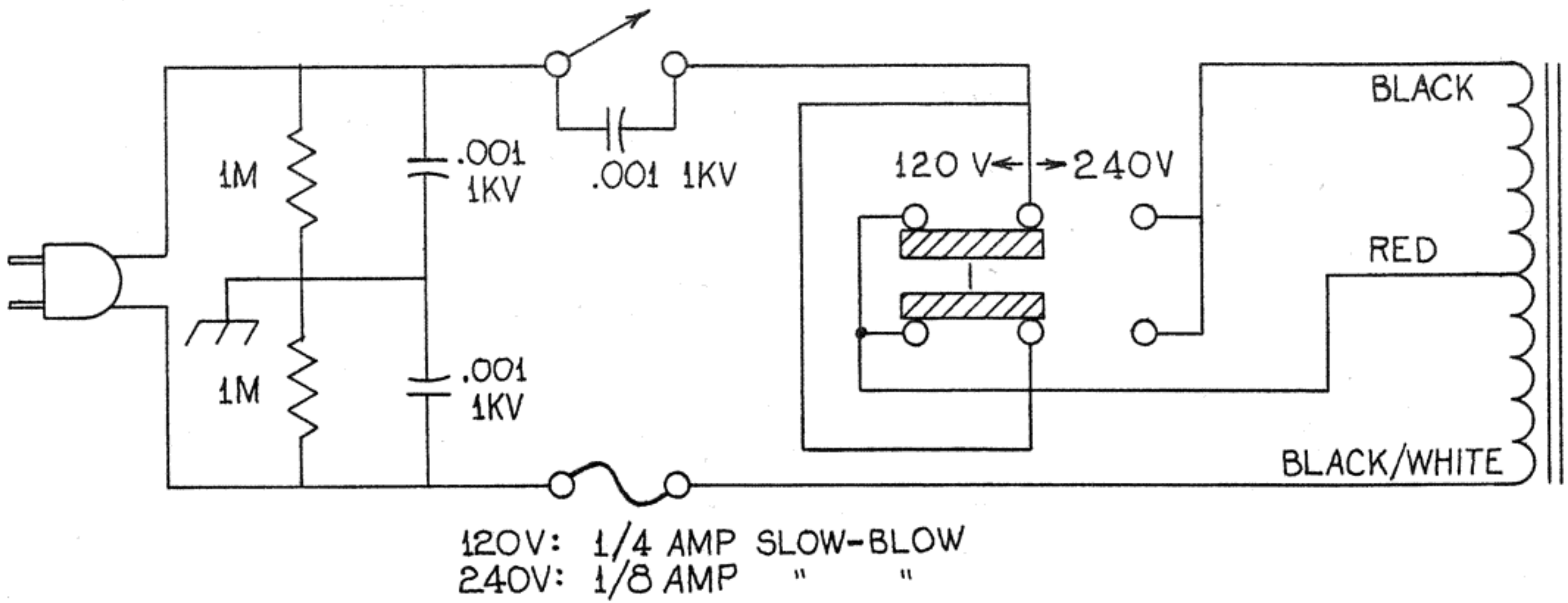

**FIGURE 20
TUNER FM DE-EMPHASIS**

