

NOTE: KIT NO. 690675-2 SHOWN. REFER TO FIGURE 3 FOR KIT NO. 692613-1\*.

ITEM NO.	PART NO.	DESCRIPTION	QTY
1	690671-1	PLATE, Base	1
2	690672-2	MOUNT, Base	1
3	4-21002-4	SCREW, Btn Hd Cap, 3/8-16 x .500 in. L	3
4	3-21000-6	SCREW, Skt Hd Cap, No. 10-32 x .625 in. L	2
5	690673-2	BRACKET, Hold-Down	1
6	2-21000-7	SCREW, Skt Hd Cap, No. 8-32 x .500 in. L	2
7	690674-1	STOP, Rear	2
8	21009-4	SETSCREW, Skt, Slfkg, 1/4-20 x .375 in. L	1
9	690499-1	RAM	1
10	—	Deleted	—
11	694925-1*	BRACKET ASSY, Vertical Reel	REF
12	694928-2	BRACKET, LH Stock Guide	1
13	470268-1	GUIDE, Stock	1
14	3-21000-1	SCREW, Skt Hd Cap, No. 8-32 x 1.00 in. L	4
15	27708-3	KNOB, Thumbscrew	2
16	21022-2	NUT, Slfkg, No. 8-32	1
17	455744-1	SHROUD, End Feed	1
18	455745-1	GUARD, End Feed	1
19	1-21899-3	WASHER, Flat, No. 8	12
20	21018-6	NUT, Hex, No. 8-32	7
21	7-22468-0	SCREW, Bdg Hd, No. 8-32 x .375 in. L	5
22	7-22468-3	SCREW, Bdg Hd, No. 8-32 x .750 in. L	1
23	22280-1	SPRING, Compression	1
24	455748-1	SHROUD, Side Feed	1
25	455749-1	GUARD, Side Feed	1
26	3-21002-4	SCREW, Btn Hd Cap, 1/4-20 x .625 in. L	1
27	21899-3	WASHER, Flat, 1/4 in.	1

\*Refer to Customer Manual 409-5128 for the detailed parts breakdown of assembly and related parts..

Figure 1

## 1. INTRODUCTION

These conversion kits are used to modify AMP-O-LECTRIC Model K Terminating Machines to accept miniature quick-change applicators. Kit No. 690675-2 is required for all end-feed and those side-feed applicators that receive the strip terminals in a horizontal position. Refer to the exploded view and parts list in Figure 1 to make sure you have all the parts required for the conversion. Kit No. 690675-2 plus Kit No. 692613-1 are required for those side-feed applicators that receive the strip terminals in a vertical position.

### NOTE



*Throughout these instructions, where reference is made to hand-cycling the machine and to the basic machine parts and assemblies, refer to Customer Manual 409-5128.*

Read the following instructions carefully before and during the installation of the conversion kits on the machine.

## 2. INSTALLATION OF CONVERSION KITS

Before starting installation of the conversion kits, remove and store mechanical feed arm or air feed operation arm from feed mechanism shaft by loosening or removing clamp screws.

### NOTE



*During installation of the conversion kit, certain parts and assemblies MUST be removed and either placed in storage or retained for installation of the kit. This kit is not recommended for Models C, J, and J/K machines.*

### CAUTION



*MAKE CERTAIN that electrical power to the machine is OFF by pulling the plug from the receptacle.*

### 2.1. Kit No. 690675-2 Installation (Figure 2)

For installation of this kit, the machine must be equipped with the proper vertical reel bracket assembly (Part No. 694925-1). For information pertaining to this assembly, refer to Customer Manual 409-5128.

1. The left-hand stock guide is required ONLY when using side-feed applicators. With guide installed on the bracket, attach the bracket to the vertical reel bracket assembly with two screws capped with knurled knobs, as shown.

2. To guide the terminal strip properly into end-feed applicators, it is necessary that the right-hand stock guide bracket be lowered by using the UPPER hold in the vertical support for the left screw, as shown.

3. Remove the two base mount screws and washers from frame and install the base mount supplied in the kit. Adjust height of the base mount as low as possible in accordance with the machine manual.

4. Hand-cycle in accordance with the machine manual until the toggle link is at its lowest position.

5. Remove the arm retaining plate by removing the four screws.

6. Loosen the setscrew in the ram, and then pivot the toggle link toward the front of the machine and slide out the toggle link pin to remove the ram.

7. Lubricate the four sides of the new ram, supplied in the kit, as specified in the machine manual.

8. Pivot the toggle link forward and install the new ram with the toggle link pin removed in Step 6. Pivot the ram back into position and tighten the setscrew provided in the kit.

9. Install the ram retaining plate with the four screws removed in Step 6.

10. Hand-cycle the machine to the rest position (top dead center).

11. All parts removed for conversion, and any unused parts of the kit, should be retained and stored.

### 2.2. Kit No. 692613-1 Installation (Figure 3)

This kit, in addition to Kit 690675-2, is required ONLY for side feed applicators that receive strip terminals in a vertical position.

1. Lay out the machine frame for holes as shown in Figure 3.

2. Drill two size "G" holes, and thread with 5/16-18 UNC-2B tap.

3. Assemble the reel support as shown and install on the machine with the two screws supplied in the kit.

## 3. INSTALLATION OF THE APPLICATOR FEED CAM

it is NECESSARY for all miniature quick-change applicators, when used in an AMP-O-LECTRIC machine, to be equipped with the CORRECT feed cam as listed on the applicator parts list (log) supplied with the applicator. CHECK the feed cam, and if necessary, replace it as described in the applicator instructions supplied with the applicator. Retain all parts that are removed.

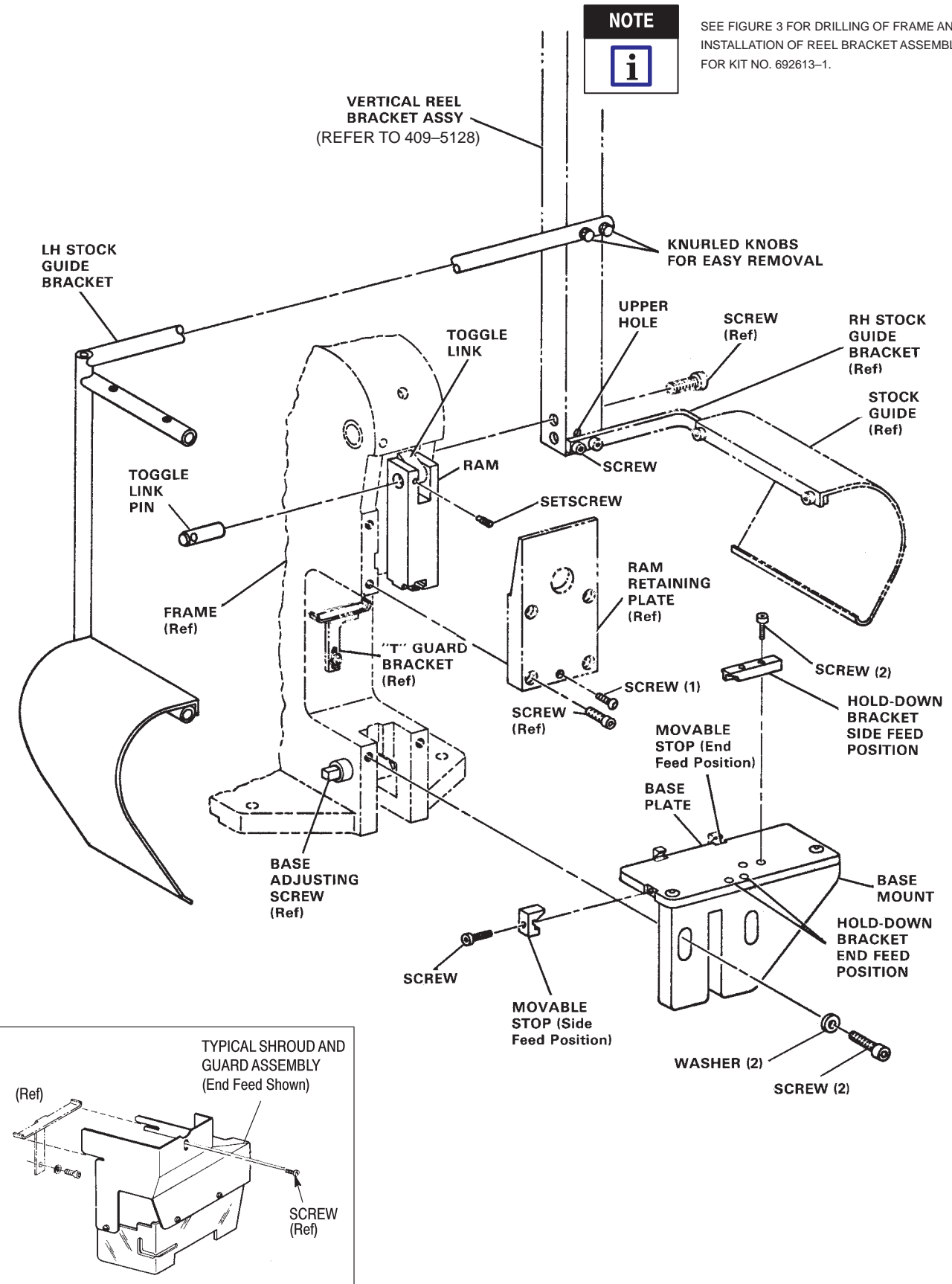

Figure 2

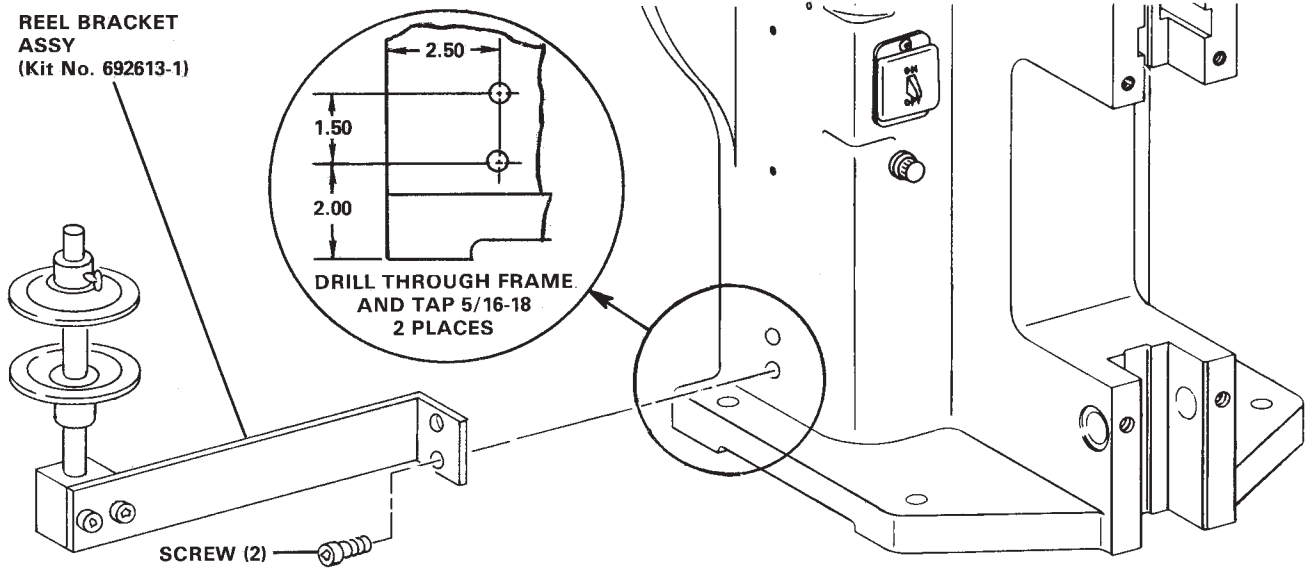

Figure 3

#### 4. INSTALLATION AND REMOVAL OF MINIATURE APPLICATOR



*MAKE CERTAIN that electrical power to the machine is OFF by pulling the plug from the receptacle.*

1. Install the movable stop on the back of the base mount for the end feed applicator or on the left end for the side feed applicator, as shown in Figure 2.
2. Place the applicator on the base mount, insert the ram post in the machine ram, then slide the applicator into position against the stops.
3. Secure the applicator with the hold-down bracket and two screws supplied in the kit. The location of the hold-down bracket differs for end feed and side feed applicators. Make certain the bracket is located correctly.
4. Load the applicator in accordance with the applicator instruction sheet supplied with the applicator.

5. Set the wire disc and insulation disc for the wire gage to be used in accordance with the data plate on the applicator and/or the applicator parts list supplied with the applicator.

6. Adjust the base mount for the correct crimp height in accordance with the machine manual.

7. Install the side feed or end feed shroud and guard assembly, for the type of applicator installed, as shown in Figure 2.

8. To remove the applicator from the machine, unload the applicator tooling according to the instruction sheet shipped with the applicator, remove the hold-down bracket, and slide the applicator away from the stops on the base mount until the ram post is clear of the machine ram.

#### 5. REVISION SUMMARY

Revisions to this instruction sheet include:

- Updated document to current requirements
- New format

# Mouser Electronics

Authorized Distributor

Click to View Pricing, Inventory, Delivery & Lifecycle Information:

[TE Connectivity:](#)

[690673-2](#)